

Key: 4560

Town of Bourne - Fiscal Year 2024

12/18/2023 6:02 pm SEQ #: 4.645

LEGAL

LAND

DETACHED

BUILDING

CURRENT OWNER				PARCEL ID				LOCATION			
BRANAGAN JUDAH 49 GREENWOOD RD ANDOVER, MA 01810				23.2-40-0				6 WASHINGTON AVE			
TRANSFER HISTORY				DOS	T	SALE PRICE	BK-PG (Cert)				
BRANAGAN JUDAH				05/06/2021	U	100,000	34083-235				
CARADIMOS PAMELA TRS				11/03/2011	QS	14,000	25811-34				
DIMODICA PHILIP J					XX		05243-00136				

CLASS	CLASS%	DESCRIPTION			BN ID	BN	CARD	
1040	100	TWO-FAMILY				1	1 of 1	
PMT NO	PMT DT	TY	DESC	AMOUNT	INSP	BY	1st	%
B-20-214	07/31/2020	1	NEW CONSTRUC	250,000	06/27/2022	RP	100	100

CD	T	AC/SF/UN	Nbhd	Infl1	N Index	ADJ BASE	SAF	Topo	Lpi	VC	CREDIT AMT	ADJ VALUE
100	S	6,825 4		100	1.00	235,700	4.45	A	1.00	R03	1.00	164,330

TOTAL	6,839 SF	ZONING		FRNT	65	ASSESSED	CURRENT	PREVIOUS
Nbhd	BBAY	NOTE	LAND	164,300	145,400			
Infl1	AVG		BUILDING	671,700	594,400			
N_Index	AVG		DETACHED	0	0			
			OTHER	0	0			
			TOTAL	836,000	739,800			

TY	QUAL	COND	DIM/NOTE	YB	UNITS	ADJ PRICE	RCNLD

PHOTO 08/09/2022

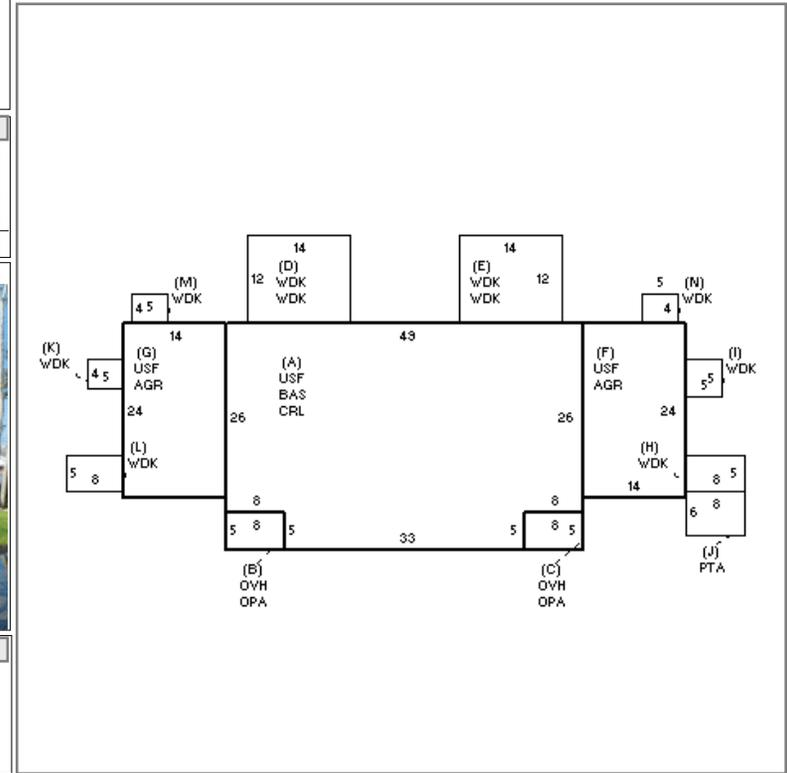
BUILDING	CD	ADJ	DESC	MEASURE	8/9/2022	SL
MODEL	1		RESIDENTIAL	LIST	8/9/2022	TL
STYLE	11	1.05	DUPLEX [100%]	REVIEW	6/27/2022	RP
QUALITY	+	1.05	AVERAGE + [100%]			
FRAME	1	1.00	WOOD FRAME [100%]			

BLDG COMMENTS

YEAR BLT	2021	SIZE ADJ	0.990	ELEMENT	CD	DESCRIPTION	ADJ	S	BAT	T	DESCRIPTION	UNITS	YB	ADJ PRICE	RCN	TOTAL RCN	671,695
NET AREA	3,630	DETAIL ADJ	1.000	FOUNDATION	3	FOUN. WALL	1.00	A	CRL	N	BSMT CRAWL	1,439		20.39	29,335	CONDITION ELEM	CD
\$NLA(RCN)	\$185	OVERALL	1.100	EXT COVER	4	VINYL	1.00	A	BAS	L	BASE AREA	1,439	2021	209.77	301,861	EXTERIOR	A
				ROOF SHAPE	1	GABLE	1.00	+	USF	L	UPPER STORY FIN	2,111	2021	99.07	209,134	INTERIOR	A
				ROOF COVER	1	ASPH/COMP SHIN	1.00	+	OPA	N	OPEN PORCH	80		82.17	6,574	KITCHEN	A
				FLOOR COVER	1	HARDWOOD	1.02	+	OVH	L	OVERHANG	80	2021	207.08	16,566	BATHS	A
				INT. FINISH	1	PLASTER	1.00	+	WDK	N	WOOD DECK	837		24.42	20,443	HEAT	A
				HEATING/COOLING	9	WARM-COOL AIR	1.03	+	AGR	N	ATT GARAGE	672		66.47	44,670	ELECT	A
				FUEL SOURCE	2	GAS	1.00	J	PTA	N	PATIO	48		17.56	843		
				USE	0		1.00	FIX	O	XTRA FIXTURES	15		2,435.09	36,526			
								KIT	O	EXTRA KITCHEN	1		5,743.50	5,744			

EFF.YR/AGE	2021 / 1
COND	1 1 %
FUNC	0
ECON	0
DEPR	0 % GD 100
RCNLD	\$671,700