

Key: 4583

Town of Bourne - Fiscal Year 2024

12/18/2023 6:02 pm SEQ #: 4.669

LEGALS

CURRENT OWNER		PARCEL ID		LOCATION	
FORLIVESI CARLA J & TAMMY A ETUX PAUL J STAIGER 5 KETTLE LANE BUZZARDS BAY, MA 02532		23.2-63-0		16 COHASSET AVE	
TRANSFER HISTORY		DOS	T	SALE PRICE	BK-PG (Cert)
FORLIVESI CARLA J & TAMMY		01/03/2017	F	1	30209-51
FORLIVESI CARLA J & TAMMY		08/20/2002	F	25,000	15494-128
STAIGER PAUL J AND		12/15/1998	A	87,000	11916-86

CLASS	CLASS%	DESCRIPTION			BN ID	BN	CARD	
1050	100	THREE-FAMILY				1	1 of 1	
PMT NO	PMT DT	TY	DESC	AMOUNT	INSP	BY	1st	%
16481	06/09/2016	2	ADDITIONS	14,500	03/11/2019	RP	0	100
11322	06/16/2011	3	ALT/RENO	4,500	05/13/2014	JB	0	100

LAND

CD	T	AC/SF/UN	Nbhd	Infl1	N Index	ADJ BASE	SAF	Topo	Lpi	VC	CREDIT AMT	ADJ VALUE
100	S	7,151 4		1.00	100 1.00	235,700	4.26	A	1.00	R02	1.00	164,850

TOTAL	7,144 SF	ZONING	1	FRNT	93	ASSESSED	CURRENT	PREVIOUS
Nbhd	BBAY	NOTE Asking \$390K:3/05; \$380K: 5/06	LAND	164,900	116,700			
Infl1	AVG		BUILDING	381,500	300,100			
N_Index	AVG		DETACHED	0	0			
			OTHER	0	0			
			TOTAL	546,400	416,800			

DETACHED

TY	QUAL	COND	DIM/NOTE	YB	UNITS	ADJ PRICE	RCNLD

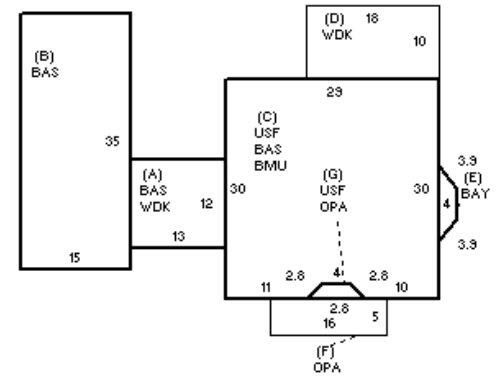

BUILDING

BUILDING	CD	ADJ	DESC	MEASURE	3/11/2019	RP
MODEL	1		RESIDENTIAL	LIST	3/11/2019	EST
STYLE	7	1.00	CONVENTIONAL [100%]	REVIEW	7/14/2023	RP
QUALITY	A	1.00	AVERAGE [100%]			
FRAME	1	1.00	WOOD FRAME [100%]			

BLDG COMMENTS

G

YEAR BLT	1940	SIZE ADJ	1.005	ELEMENT	CD	DESCRIPTION	ADJ	S	BAT	T	DESCRIPTION	UNITS	YB	ADJ PRICE	RCN	TOTAL RCN	501,922															
NET AREA	2,427	DETAIL ADJ	1.000	FOUNDATION	4	FLR/WALL(FULL)	1.00	+	WDK	N	WOOD DECK	336		24.04	8,078																	
\$NLA(RCN)	\$207	OVERALL	1.120	EXT COVER	4	VINYL	1.00	+	BAS	L	BASE AREA	1,539	1940	206.50	317,797																	
				ROOF SHAPE	1	GABLE	1.00	C	BMU	N	BSMT UNFINISHED	858		41.04	35,217																	
				ROOF COVER	1	ASPH/COMP SHIN	1.00	+	USF	L	UPPER STORY FIN	870	1940	121.17	105,419																	
				FLOOR COVER	1	HARDWOOD	1.02	E	BAY	L	BAYWINDOW	18	1940	203.86	3,670																	
				INT. FINISH	1	PLASTER	1.00	+	OPA	N	OPEN PORCH	92		80.90	7,443																	
				HEATING/COOLING	1	FORCED AIR	1.00	F21	O	FPL 2S 1OP	1		9,915.40	9,915																		
				FUEL SOURCE	2	GAS	1.00	FIX	O	XTRA FIXTURES	6		2,397.15	14,383																		
				USE	0		1.00																									
				<table border="1"> <thead> <tr> <th>CONDITION ELEM</th> <th>CD</th> </tr> </thead> <tbody> <tr> <td>EXTERIOR</td> <td>A</td> </tr> <tr> <td>INTERIOR</td> <td>A</td> </tr> <tr> <td>KITCHEN</td> <td>A</td> </tr> <tr> <td>BATHS</td> <td>A</td> </tr> <tr> <td>HEAT</td> <td>A</td> </tr> <tr> <td>ELECT</td> <td>A</td> </tr> </tbody> </table>														CONDITION ELEM	CD	EXTERIOR	A	INTERIOR	A	KITCHEN	A	BATHS	A	HEAT	A	ELECT	A	
CONDITION ELEM	CD																															
EXTERIOR	A																															
INTERIOR	A																															
KITCHEN	A																															
BATHS	A																															
HEAT	A																															
ELECT	A																															
				<table border="1"> <thead> <tr> <th>EFF.YR/AGE</th> <td colspan="2">1995 / 27</td> </tr> </thead> <tbody> <tr> <td>COND</td> <td>24</td> <td>24 %</td> </tr> <tr> <td>FUNC</td> <td>0</td> <td></td> </tr> <tr> <td>ECON</td> <td>0</td> <td></td> </tr> <tr> <td>DEPR</td> <td>24</td> <td>% GD 76</td> </tr> </tbody> </table>														EFF.YR/AGE	1995 / 27		COND	24	24 %	FUNC	0		ECON	0		DEPR	24	% GD 76
EFF.YR/AGE	1995 / 27																															
COND	24	24 %																														
FUNC	0																															
ECON	0																															
DEPR	24	% GD 76																														
				<table border="1"> <tr> <td>RCNLD</td> <td>\$381,500</td> </tr> </table>														RCNLD	\$381,500													
RCNLD	\$381,500																															