

Key: 4675

Town of Bourne - Fiscal Year 2024

12/18/2023 6:02 pm SEQ #: 4.769

LEGAL

CURRENT OWNER				PARCEL ID				LOCATION			
CAPE COD CANAL APTS LLC C/O NEWMAN PROPERTIES 8 ALTON PLACE BROOKLINE, MA 02446				23.2-191-0				9 THOMAS AVE			
TRANSFER HISTORY				DOS	T	SALE PRICE	BK-PG (Cert)				
CAPE COD CANAL APTS LLC				06/15/2017	QS	750,000	30561-138				
9 THOMAS AVE LLC				11/22/2013	QS	507,000	27839-236				
GOOD BUILDERS INC				08/08/2012	F	100	26571-55				

CLASS	CLASS%	DESCRIPTION			BN ID	BN	CARD	
1110	100	APT - 4 TO 8 UNITS				1	1 of 1	
PMT NO	PMT DT	TY	DESC	AMOUNT	INSP	BY	1st	%
19705	07/31/2019	3	ALT/RENO	26,500	04/12/2021	TL	100	100
19650	07/25/2019	5	DEMOLITIONS		04/12/2021	TL	100	100
		12	CYCLICAL		06/12/2017	BC	100	100

LAND

CD	T	AC/SF/UN	Nbhd	Infl1	N Index	ADJ BASE	SAF	Topo	Lpi	VC	CREDIT AMT	ADJ VALUE
112	U		6 APT	1.00	100	92,000	1.00	A	1.00	APE	2.50	552,000

TOTAL	19,342 SF	ZONING	FRNT	0	ASSESSED	CURRENT	PREVIOUS
Nbhd	APTS	N O T E BLDG 2 ... slight view of canal	LAND	552,000	525,000		
Infl1	AVG		BUILDING	309,500	297,600		
N_Index	AVG		DETACHED	2,900	2,600		
			OTHER	0	0		
			TOTAL	864,400	825,200		

DETACHED

TY	QUAL	COND	DIM/NOTE	YB	UNITS	ADJ PRICE	RCNLD	PHOTO
PAV	A	1.00	20 0.80		3,000	1.20	2,900	06/12/2017

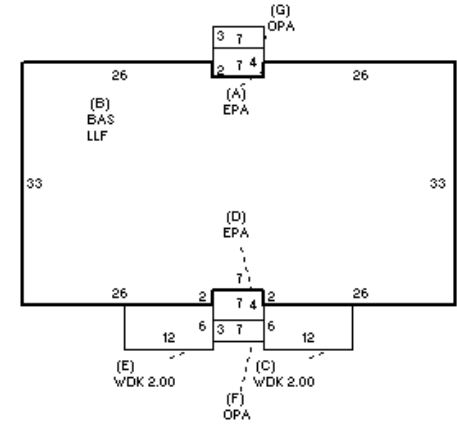

BUILDING

BUILDING	CD	ADJ	DESC	MEASURE	6/12/2017	BC
MODEL	5		CIM-5	LIST	4/12/2021	EST
STYLE	15	1.00	APARTMENT [100%]	REVIEW	4/12/2021	TL
QUALITY	A	1.00	AVERAGE [100%]			
FRAME	1	1.00	WOOD FRAME [100%]			

BLDG COMMENTS

LOADING

YEAR BLT	1973	SIZE ADJ	1.000	ELEMENT	CD	DESCRIPTION	ADJ	S	BAT	T	DESCRIPTION	UNITS	YB	ADJ PRICE	RCN	TOTAL RCN	372,842
NET AREA	5,757	DETAIL ADJ	1.349	FOUNDATION	4	FLR & WALL	1.00	+	EPA	N	ENCL PORCH	56		30.80	1,725		
\$NLA(RCN)	\$65	OVERALL	1.000	EXT. COVER	4	VINYL	1.00	B	LLF	L	LOW-LEV FIN	1,919	1973	44.61	85,616		
				ROOF SHAPE	1	GABLE	1.00	B	BAS	L	BASE AREA	1,919	1973	78.33	150,308		
				ROOF COVER	1	ASPH/CMP SHIN	1.00	+	WDK	N	WOOD DECK	288		24.50	7,056		
				FLOOR COVER	1	HARDWOOD	1.00	+	OPA	N	OPEN PORCH	42		16.10	676		
				INT. FINISH	2	DRYWALL	1.00	USF	L	L	UP-STRY FIN	1,919	1973	66.42	127,461		
				HEATING/COOL	2	HOT WATER	1.02										
				FUEL SOURCE	2	GAS	1.00										
				NAF	140	140	1.40										

CONDITION ELEM	CD
EXTERIOR	G
INTERIOR	G
CDN/APP	E

EFF. YR/AGE	2005 / 17
COND	17 17 %
FUNC	0
ECON	0
DEPR	17 % GD 83

RCNLD	\$309,500
-------	-----------