

Key: 4679

Town of Bourne - Fiscal Year 2024

12/18/2023 6:02 pm SEQ #: 4.772

LEGAL

CURRENT OWNER				PARCEL ID				LOCATION			
CAPE COD CANAL APARTMENTS LLC 8 ALTON PLACE BROOKLINE, MA 02446				23.2-192-0				21 THOMAS AVE			
TRANSFER HISTORY				DOS	T	SALE PRICE	BK-PG (Cert)				
CAPE COD CANAL APARTMENTS				04/28/2016	QS	635,000	29610-65				
21 THOMAS AVENUE LLC				08/08/2012	QS	465,000	26571-72				
GOOD BUILDERS INC				08/08/2012	F	100	26571-55				

CLASS	CLASS%	DESCRIPTION			BN ID	BN	CARD	
1110	100	APT - 4 TO 8 UNITS				1	1 of 1	
PMT NO	PMT DT	TY	DESC	AMOUNT	INSP	BY	1st	%
161016	11/21/2016	12	CYCLICAL		06/12/2017	BC	100	100
13891	12/17/2013	3	ALT/RENO	4,650	06/12/2017	BC	100	100
		13	OTHER	4,850	02/04/2014	JB	100	100

LAND

CD	T	AC/SF/UN	Nbhd	Infl1	N Index	ADJ BASE	SAF	Topo	Lpi	VC	CREDIT AMT	ADJ VALUE
112	U	6 APT	1.00	100	1.00	100	1.00	A	1.00	APE	2.50	552,000

TOTAL	20,000 SF	ZONING	FRNT	0	ASSESSED	CURRENT	PREVIOUS
Nbhd	APTS	N O T E BLDG 3	LAND	552,000	525,000		
Infl1	AVG		BUILDING	283,500	272,600		
N_Index	AVG		DETACHED	1,900	1,800		
			OTHER	0	0		
			TOTAL	837,400	799,400		

DETACHED

TY	QUAL	COND	DIM/NOTE	YB	UNITS	ADJ PRICE	RCNLD
PAV	A	1.00	20 0.80		2,000	1.20	1,900

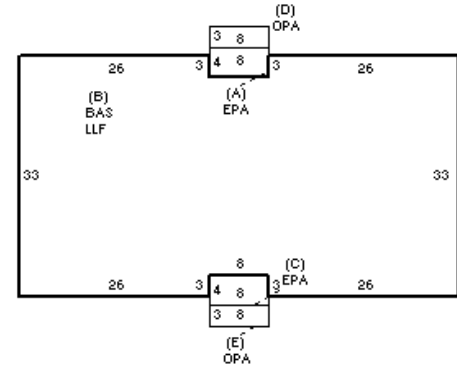

BUILDING

BUILDING	CD	ADJ	DESC	MEASURE	6/12/2017	BC
MODEL	5		CIM-5	LIST	6/12/2017	EST
STYLE	15	1.00	APARTMENT [100%]	REVIEW	6/12/2017	BC
QUALITY	A	1.00	AVERAGE [100%]			
FRAME	1	1.00	WOOD FRAME [100%]			

BLDG COMMENTS

LOADING

YEAR BLT	1973	SIZE ADJ	1.000	ELEMENT	CD	DESCRIPTION	ADJ	S	BAT	T	DESCRIPTION	UNITS	YB	ADJ PRICE	RCN	TOTAL RCN	368,198
NET AREA	5,796	DETAIL ADJ	1.349	FOUNDATION	4	FLR & WALL	1.00	+	EPA	N	ENCL PORCH	64		30.80	1,971		
\$NLA(RCN)	\$64	OVERALL	1.000	EXT. COVER	4	VINYL	1.00	B	LLF	L	LOW-LEV FIN	1,932	1973	44.57	86,103		
				ROOF SHAPE	1	GABLE	1.00	B	BAS	L	BASE AREA	1,932	1973	78.24	151,164		
				ROOF COVER	1	ASPH/CMP SHIN	1.00	+	OPA	N	OPEN PORCH	48		16.10	773		
				FLOOR COVER	1	HARDWOOD	1.00		USF	L	UP-STRY FIN	1,932	1973	66.35	128,187		
				INT. FINISH	2	DRYWALL	1.00										
				HEATING/COOL	2	HOT WATER	1.02										
				FUEL SOURCE	2	GAS	1.00										
				NAF	140	140	1.40										
																CONDITION ELEM	CD
																EXTERIOR	G
																INTERIOR	G
																CDN/APP	G
																EFF.YR/AGE	1997 / 25
																COND	23 23 %
																FUNC	0
																ECON	0
																DEPR	23 % GD 77
																RCNLD	\$283,500