

Key: 4814

Town of Bourne - Fiscal Year 2024

12/18/2023 6:02 pm SEQ #: 4.931

LEGAL

CURRENT OWNER				PARCEL ID				LOCATION			
POIRIER PHILIP ET UX PERIAN A POIRIER 10 JEFFERSON RD BOURNE, MA 02532				23.4-11-0				10 JEFFERSON RD			
TRANSFER HISTORY				DOS	T	SALE PRICE	BK-PG (Cert)				
POIRIER PHILIP ET UX SCHLOTTERBECK LEWIS C				12/29/2009	QS XX	450,000	24270-30 01253-0027				

CLASS	CLASS%	DESCRIPTION			BN ID	BN	CARD	
1010	100	SINGLE FAMILY				1	1 of 1	
PMT NO	PMT DT	TY	DESC	AMOUNT	INSP	BY	1st	%
EXB-21-822	11/10/2021	6	FENCE	3,600			100	100
15565	07/08/2015	6	FENCE	350	02/11/2016		100	100
14545	07/10/2014	2	ADDITIONS	20,000	11/02/2015	SW	100	100
14498	06/25/2014	9	DECK	2,000	11/02/2015	SW	100	100
10749	12/15/2010	9	DECK	2,000	11/02/2015	SW	100	100

LAND

CD	T	AC/SF/UN	Nbhd	Infl1	N Index	ADJ BASE	SAF	Topo	Lpi	VC	CREDIT AMT	ADJ VALUE				
100	S	7,808	7	1.00	100	1.00	100	1.00	848,520	3.93	A	1.00	CEX	3.60		597,150

TOTAL	7,797 SF	ZONING	1	FRNT	0	ASSESSED	CURRENT	PREVIOUS
Nbhd	GRAY GAB	NOTE	LAND	597,200	528,500			
Infl1	AVG		BUILDING	395,100	349,600			
N_Index	AVG		DETACHED	0	0			
			OTHER	0	0			
			<b>TOTAL</b>	<b>992,300</b>	<b>878,100</b>			

DETACHED

TY	QUAL	COND	DIM/NOTE	YB	UNITS	ADJ PRICE	RCNLD	PHOTO
								11/02/2015



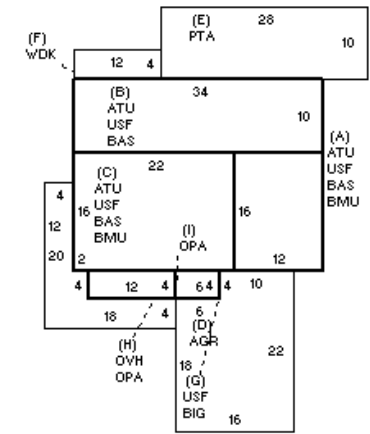

BUILDING

BUILDING	CD	ADJ	DESC	MEASURE	11/13/2018	TL
MODEL	1		RESIDENTIAL	LIST	11/13/2018	TL
STYLE	5	1.00	COLONIAL [100%]	REVIEW		
QUALITY	A	1.00	AVERAGE [100%]			
FRAME	1	1.00	WOOD FRAME [100%]			

YEAR BLT	1939	SIZE ADJ	1.010	ELEMENT	CD	DESCRIPTION	ADJ	S	BAT	T	DESCRIPTION	UNITS	YB	ADJ PRICE	RCN	TOTAL RCN	443,896
NET AREA	1,840	DETAIL ADJ	1.000	FOUNDATION	4	FLR/WALL(FULL)	1.00	+	BMU	N	BSMT UNFINISHED	544		49.28	26,809	CONDITION ELEM	CD
\$NLA(RCN)	\$241	OVERALL	1.060	EXT COVER	1	WOOD SHINGLE	1.02	A	BAS	L	BASE AREA	192	2014	212.30	40,762	EXTERIOR	G
				ROOF SHAPE	1	GABLE	1.00	+	USF	L	UPPER STORY FIN	884	1939	115.25	101,882	INTERIOR	A
				ROOF COVER	1	ASPH/COMP SHIN	1.00	A	ATU	N	ATTIC UNF	192		45.25	8,688	KITCHEN	G
				FLOOR COVER	1	HARDWOOD	1.02	+	BAS	L	BASE AREA	692	1939	212.31	146,915	BATHS	G
				INT. FINISH	2	DRYWALL	1.00	B	ATU	N	ATTIC UNF	340		45.25	15,385	HEAT	A
				HEATING/COOLING	2	HOT WATER	1.02	C	ATU	N	ATTIC UNF	352		45.25	15,927	ELECT	U
				FUEL SOURCE	2	GAS	1.00	D	AGR	N	ATT GARAGE	328		74.72	24,509		
				USE	0		1.00	E	PTA	N	PATIO	280		14.56	4,076	EFF.YR/AGE	2008 / 14
								F	WDK	N	WOOD DECK	48		67.87	3,258	COND	11 11 %
								G	BIG	N	BUILT-IN GARAGE	24		116.43	2,794	FUNC	0
								G	USF	L	UPPER STORY FIN	24	2014	115.27	2,766	ECON	0
								+	OPA	N	OPEN PORCH	192		69.97	13,435	DEPR	11 % GD 89
								H	OVH	L	OVERHANG	48	2014	193.89	9,307	RCNLD	\$395,100
								FIX	O	XTRA FIXTURES	6		2,280.02	13,680			
								GFP	O	GAS FIREPLACE	2		6,851.85	13,704			