

Key: 482

Town of Bourne - Fiscal Year 2024

12/18/2023 6:02 pm SEQ #: 478

LEGALS

CURRENT OWNER				PARCEL ID				LOCATION			
TUCKER LANCE & SHEILA B TRS OF 21 SHAWMUT RD NOM TRUST 31 LEDYARD STREET WELLESLEY, MA 02481-1608				4.1-67-0				21 SHAWMUT RD			
TRANSFER HISTORY				DOS	T	SALE PRICE	BK-PG (Cert)				
TUCKER LANCE & SHEILA B T				07/13/2001	F	14034-187	1				
TUCKER LANCE K & YOUNG W C BURRISS				10/13/2000	QS XX	405,000	13297-96 02097-0231				

CLASS	CLASS%	DESCRIPTION		BN ID	BN	CARD	
1010	100	SINGLE FAMILY			1	1 of 1	
PMT NO	PMT DT	TY	DESC	AMOUNT	INSP	BY	1st %
EXB-22-306	05/18/2022	3	ALT/RENO	4,000	06/06/2023	TL	100 100
B-22-48	03/29/2022	1	NEW CONSTRUCT	1,175,000	06/06/2023	TL	100 100
D-22-10	03/29/2022	5	DEMOLITIONS	25,000	05/19/2022	TL	100 100
950410	08/23/1995	9	DECK	2,000	07/30/1996	JS	100 100

LAND

CD	T	AC/SF/UN	Nbhd	Infl1	N Index	ADJ BASE	SAF	Topo	Lpi	VC	CREDIT AMT	ADJ VALUE					
100	S	16,415	1	1.00	100	1.00	100	1.00	518,540	2.02	A	1.00	BA+	2.20			394,640

TOTAL	16,422 SF	ZONING	1	FRNT	111	ASSESSED	CURRENT	PREVIOUS
Nbhd	N SAG	N O T E waternview Also frontage on Cataumet Rd	LAND	394,600	349,300			
Infl1	AVG		BUILDING	782,200	0			
N_Index	AVG		DETACHED	0	0			
			OTHER	0	0			
			TOTAL	1,176,800	349,300			

DETACHED

TY	QUAL	COND	DIM/NOTE	YB	UNITS	ADJ PRICE	RCNLD

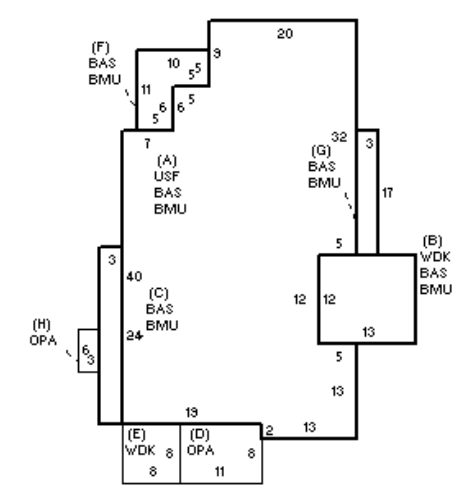

BLDG COMMENTS

BUILDING

BUILDING	CD	ADJ	DESC	MEASURE	6/15/2022	TL
MODEL	1		RESIDENTIAL	LIST	10/26/2022	EST
STYLE	8	1.10	CONTEMPORARY [100%]	REVIEW	10/6/2023	SL
QUALITY	G	1.10	GOOD [100%]			
FRAME	1	1.00	WOOD FRAME [100%]			

YEAR BLT	2022	SIZE ADJ	0.990	ELEMENT	CD	DESCRIPTION	ADJ
NET AREA	3,511	DETAIL ADJ	1.000	FOUNDATION	4	FLR/WALL(FULL)	1.00
\$NLA(RCN)	\$223	OVERALL	1.170	EXT COVER	1	WOOD SHINGLE	1.02
CAPACITY				ROOF SHAPE	1	GABLE	1.00
STORIES	2	ADJ	1.00	ROOF COVER	1	ASPH/COMP SHIN	1.00
ROOMS	8		1.00	FLOOR COVER	1	HARDWOOD	1.02
BEDROOMS	3		1.00	INT. FINISH	1	PLASTER	1.00
BATHROOMS	3		1.00	HEATING/COOLING	9	WARM-COOL AIR	1.03
FIXTURES	17		1.00	FUEL SOURCE	2	GAS	1.00
GARAGE CAPACITY	1		1.00	USE	0		1.00
% BSMT FINISH	0		1.00				
# OF HALF BATHS	1		1.00				
# OF UNITS	1		1.00				

S	BAT	T	DESCRIPTION	UNITS	YB	ADJ PRICE	RCN
+	BMU	N	BSMT UNFINISHED	1,935		37.78	73,106
+	BAS	L	BASE AREA	1,935	2022	225.67	436,669
A	USF	L	UPPER STORY FIN	1,576	2022	132.47	208,771
+	OPA	N	OPEN PORCH	106		87.42	9,267
+	WDK	N	WOOD DECK	220		33.00	7,260
	BMG	O	BSMT GARAGE	1		9,082.00	9,082
	FIX	O	XTRA FIXTURES	11		2,713.44	29,848
	GFP	O	GAS FIREPLACE	1		8,154.40	8,154

TOTAL RCN	782,157
CONDITION ELEM CD	
EXTERIOR	A
INTERIOR	A
KITCHEN	A
BATHS	A
HEAT	A
ELECT	A
EFF.YR/AGE 2022 / 0	
COND	0 0 %
FUNC	0 uc
ECON	0
DEPR	0 % GD 100
RCNLD	\$782,200