

Key: 4850

Town of Bourne - Fiscal Year 2024

12/18/2023 6:02 pm SEQ #: 4.968

LEGALS LAND

CURRENT OWNER				PARCEL ID				LOCATION				
TUDOR CHERRY INVESTORS II LLC C/O ALAN DOYLE 6 BRIARWOOD DR BARRINGTON, RI 02806				24.0-1-0				82 SANDWICH RD				
TRANSFER HISTORY				DOS	T	SALE PRICE	BK-PG (Cert)					
TUDOR CHERRY INVESTORS II				11/03/2014	QS	1,325,000	28485-119					
GARLAND AMY T EXECUTRIX				12/05/2012	F		26918-299					
GARLAND HOLDING CO LLC				03/28/2012	F	1	26198-39					
CD	T	AC/SF/UN	Nbhd	Infl1	N Index	ADJ BASE	SAF	Topo	Lpi	VC	CREDIT AMT	ADJ VALUE
112	U		15 APT	1.00	100	1.00	100	1.00	1.00	APA	1.00	552,000

CLASS	CLASS%	DESCRIPTION		BN ID	BN	CARD		
1120	100	APT - MORE THAN 8 UT			1	1 of 1		
PMT NO	PMT DT	TY	DESC	AMOUNT	INSP	BY	1st	%
20242	03/19/2020	3	ALT/RENO	8,450			100	100
17307	05/01/2017	9	DECK	40,000	05/14/2018	BC	100	100
15589	07/14/2015	3	ALT/RENO	10,000	05/14/2018	BC	100	100
15004	01/06/2015	3	ALT/RENO	4,500	05/14/2018	BC	100	100
09490	10/07/2009	3	ALT/RENO	43,990	08/26/2010	JB	100	100

TOTAL	31,145 SF	ZONING	FRNT	0	ASSESSED	CURRENT	PREVIOUS
Nbhd	APTS	NOTE	LAND	552,000	525,000		
Infl1	AVG		BUILDING	1,842,400	1,772,400		
N_Index	AVG		DETACHED	9,300	8,600		
			OTHER	0	0		
		TOTAL		2,403,700	2,306,000		

DETAILED

TY	QUAL	COND	DIM/NOTE	YB	UNITS	ADJ PRICE	RCNLD
SW2	A	1.00	10 0.90	8 X 6	48	21.80	900
PAV	A	1.00	30 0.70		10,000	1.20	8,400

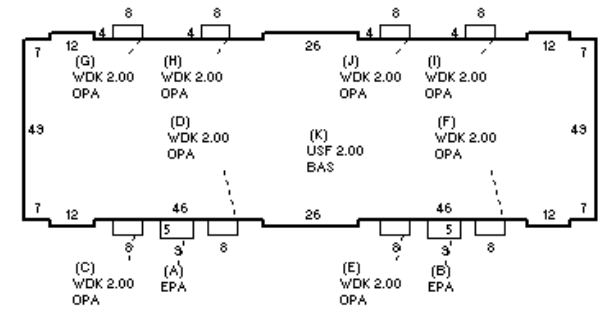

BUILDING

BUILDING	CD	ADJ	DESC	MEASURE	5/14/2018	BC
MODEL	5		CIM-5	LIST	5/14/2018	EST
STYLE	15	1.00	APARTMENT [100%]	REVIEW	7/6/2018	BC
QUALITY	+	1.05	AVERAGE + [100%]			
FRAME	1	1.00	WOOD FRAME [100%]			

BLDG COMMENTS

LOADING

YEAR BLT	1970	SIZE ADJ	1.000	ELEMENT	CD	DESCRIPTION	ADJ	S	BAT	T	DESCRIPTION	UNITS	YB	ADJ PRICE	RCN	TOTAL RCN	2,791,533
NET AREA	23,532	DETAIL ADJ	2.403	FOUNDATION	4	FLR & WALL	1.00	+	EPA	N	ENCL PORCH	90		32.34	2,911	CONDITION ELEM	CD
\$NLA(RCN)	\$119	OVERALL	1.000	EXT. COVER	12	BRICK VENEER	1.05	+	OPA	N	OPEN PORCH	256		16.91	4,328	EXTERIOR	A
				ROOF SHAPE	1	GABLE	1.00	+	WDK	N	WOOD DECK	512		25.72	13,171	INTERIOR	A
				ROOF COVER	1	ASPH/CMP SHIN	1.00	K	BAS	L	BASE AREA	7,844	1970	131.04	1,027,865	CDN/APP	A
				FLOOR COVER	3	W/W CARPET	1.00	K	USF	L	UP-STRY FIN	15,688	1970	111.12	1,743,258		
				INT. FINISH	2	DRYWALL	1.00										
				HEATING/COOL	5	ELECTRIC BB	0.98										
				FUEL SOURCE	3	ELECTRIC	1.00										
				NAF	250	250	2.50										
																EFF.YR/AGE	1979 / 43
																COND	34 34 %
																FUNC	0
																ECON	0
																DEPR	34 % GD 66
																RCNLD	\$1,842,400