

Key: 4928

Town of Bourne - Fiscal Year 2024

12/18/2023 6:02 pm SEQ #: 5.053

LEGAL

| CURRENT OWNER | | | | PARCEL ID | | | | LOCATION | | | |
|--|--|--|--|------------|----|-------------------|--|---------------------|--|--|--|
| HARTSHORN BRUCE & MERYDEN TRS HARTSHORN-KIRBY FAM REVOC TRUS PO BOX 2125 SANDWICH, MA 02563 | | | | 24.1-19-0 | | | | 29-31 OLD BRIDGE RD | | | |
| TRANSFER HISTORY | | | | DOS | T | SALE PRICE | | BK-PG (Cert) | | | |
| HARTSHORN BRUCE & MERYDEN | | | | 03/18/2016 | F | 10 29519-209 | | | | | |
| HARTSHORN BRUCE R ETUX | | | | 05/30/2002 | QS | 239,000 15208-109 | | | | | |
| ZORN MELISSA | | | | 07/13/1999 | A | 146,200 12402-41 | | | | | |

| CLASS | CLASS% | DESCRIPTION | | | BN ID | BN | CARD | |
|--------|------------|-------------|----------|--------|------------|----|--------|-----|
| 1040 | 100 | TWO-FAMILY | | | | 1 | 1 of 1 | |
| PMT NO | PMT DT | TY | DESC | AMOUNT | INSP | BY | 1st | % |
| 14005 | 01/06/2014 | 3 | ALT/RENO | | | | 100 | 100 |
| 12866 | 12/07/2012 | 3 | ALT/RENO | 3,400 | | | 100 | 100 |
| 910126 | 04/11/1991 | 3 | ALT/RENO | 1,000 | 02/01/1992 | HS | 100 | 100 |

LAND

| CD | T | AC/SF/UN | Nbhd | Infl1 | N Index | ADJ BASE | SAF | Topo | Lpi | VC | CREDIT AMT | ADJ VALUE |
|-----|---|----------|------|----------|----------|----------|------|------|------|-----|------------|-----------|
| 100 | S | 10,000 4 | | 100 1.00 | 100 1.00 | 235,700 | 3.13 | A | 1.00 | R03 | 1.00 | 169,320 |

| TOTAL | 10,019 SF | ZONING | 1 | FRNT | 0 | ASSESSED | CURRENT | PREVIOUS |
|---------|-----------|--------|----------|---------|---------|--------------|----------------|----------------|
| Nbhd | BBAY | NOTE | | | | LAND | 169,300 | 149,900 |
| Infl1 | AVG | | LAND | 283,200 | 250,600 | | | |
| N_Index | AVG | | DETACHED | 7,900 | 7,500 | | | |
| | | | OTHER | 0 | 0 | | | |
| | | | | | | TOTAL | 460,400 | 408,000 |

DETAILED

| TY | QUAL | COND | DIM/NOTE | YB | UNITS | ADJ PRICE | RCNLD | PHOTO |
|-----|------|---------|--------------|----|-------|-----------|-------|------------|
| DGF | A | 1.00 30 | 0.70 12 X 20 | | 240 | 46.93 | 7,900 | 06/10/2022 |
| SHF | A | 1.00 A | 0.75 7 X 10 | | | 0.00 | | |

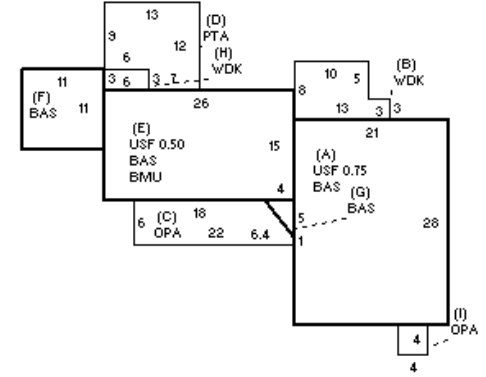

BUILDING

| BUILDING | CD | ADJ | DESC | MEASURE | 5/4/2022 | RP |
|----------|----|------|---------------------|---------|----------|-----|
| MODEL | 1 | | RESIDENTIAL | LIST | 5/4/2022 | EST |
| STYLE | 7 | 1.00 | CONVENTIONAL [100%] | REVIEW | 5/4/2022 | RP |
| QUALITY | A | 1.00 | AVERAGE [100%] | | | |
| FRAME | 1 | 1.00 | WOOD FRAME [100%] | | | |

BLDG COMMENTS

G

| YEAR BLT | 1880 | SIZE ADJ | 1.010 | ELEMENT | CD | DESCRIPTION | ADJ | S | BAT | T | DESCRIPTION | UNITS | YB | ADJ PRICE | RCN | TOTAL RCN | 372,674 | | |
|------------|-------|------------|-------|-----------------|----|----------------|------|---|-----|---|-----------------|-------|------|-----------|---------|----------------|---------|------------|------------|
| NET AREA | 1,745 | DETAIL ADJ | 1.000 | FOUNDATION | 3 | FOUN. WALL | 1.00 | + | BAS | L | BASE AREA | 1,109 | 1880 | 201.64 | 223,620 | CONDITION ELEM | CD | | |
| \$NLA(RCN) | \$214 | OVERALL | 1.040 | EXT COVER | 1 | WOOD SHINGLE | 1.02 | + | USF | L | UPPER STORY FIN | 636 | 1880 | 114.21 | 72,639 | EXTERIOR | A | | |
| | | | | ROOF SHAPE | 1 | GABLE | 1.00 | + | WDK | N | WOOD DECK | 107 | | 41.51 | 4,441 | INTERIOR | A | | |
| | | | | ROOF COVER | 1 | ASPH/COMP SHIN | 1.00 | + | OPA | N | OPEN PORCH | 138 | | 72.07 | 9,946 | KITCHEN | A | | |
| | | | | FLOOR COVER | 1 | HARDWOOD | 1.02 | D | PTA | N | PATIO | 138 | | 15.01 | 2,071 | BATHS | A | | |
| | | | | INT. FINISH | 1 | PLASTER | 1.00 | E | BMU | N | BSMT UNFINISHED | 390 | | 64.48 | 25,148 | HEAT | A | | |
| | | | | HEATING/COOLING | 1 | FORCED AIR | 1.00 | | CRL | N | BSMT CRAWL | 963 | | 21.38 | 20,585 | ELECT | A | | |
| | | | | FUEL SOURCE | 1 | OIL | 1.00 | | FIX | O | XTRA FIXTURES | 4 | | 2,236.83 | 8,947 | | | | |
| | | | | USE | 0 | | 1.00 | | KIT | O | EXTRA KITCHEN | 1 | | 5,276.20 | 5,276 | | | | |
| | | | | | | | | | | | | | | | | | | EFF.YR/AGE | 1995 / 27 |
| | | | | | | | | | | | | | | | | | | COND | 24 24 % |
| | | | | | | | | | | | | | | | | | | FUNC | 0 |
| | | | | | | | | | | | | | | | | | | ECON | 0 |
| | | | | | | | | | | | | | | | | | | DEPR | 24 % GD 76 |
| | | | | | | | | | | | | | | | | | | RCNLD | \$283,200 |