

Key: 5229

Town of Bourne - Fiscal Year 2024

12/18/2023 6:02 pm SEQ #: 5.372

LEGAL

CURRENT OWNER				PARCEL ID				LOCATION							
BAPTISTE PETER J & SHARON E BAPTISTE PO BOX 203 MONUMENT BEACH, MA 02553				26.0-19-0				91 OLD DAM RD							
				TRANSFER HISTORY				DOS	T	SALE PRICE	BK-PG (Cert)				
				BAPTISTE PETER J & BAPTISTE PETER J BAPTISTE DOMINGO &				07/18/2003 06/01/2001 11/13/1946	F A X	1 1 659-229	17282-348 13894-175				
CD	T	AC/SF/UN	Nbhd	Infl1	N Index	ADJ BASE	SAF	Topo	Lpi	VC	CREDIT AMT	ADJ VALUE			
100	S	40,000	6	1.00	100	1.00	100	1.00	294,625	1.00	A	1.00	R07	1.25	270,490
300	A	1,000	6	1.00	100	1.00	100	1.00	20,375	1.00	A	1.00	R07	1.25	20,380
300	A	7,768	6	1.00	100	1.00	100	1.00	8,150	1.00	60	0.40	R07	1.25	710F 53,220 10,090

LAND

TOTAL	9.686 Acres	ZONING	1	FRNT	0	ASSESSED	CURRENT	PREVIOUS
Nbhd	BOURNE	N O T E Frontage for one house lot per owner's appraisal and area shown as upland; remainder water source for abutting bogs same topo as marshland	LAND	300,960	267,400			
Infl1	AVG		BUILDING	704,100	629,900			
N_Index	AVG		DETACHED	0	0			
			OTHER	0	0			
			TOTAL	1,005,060	897,300			

DETACHED

TY	QUAL	COND	DIM/NOTE	YB	UNITS	ADJ PRICE	RCNLD	PHOTO	01/01/2003
									

BUILDING

BUILDING	CD	ADJ	DESC	MEASURE	5/15/2018	TL
MODEL	1		RESIDENTIAL	LIST	5/15/2018	EST
STYLE	8	1.10	CONTEMPORARY [100%]	REVIEW		
QUALITY	+	1.05	AVERAGE + [100%]			
FRAME	1	1.00	WOOD FRAME [100%]			

INDING

YEAR BLT	2005	SIZE ADJ	0.995	ELEMENT	CD	DESCRIPTION	ADJ	S	BAT	T	DESCRIPTION	UNITS	YB	ADJ PRICE	RCN	TOTAL RCN	773,721
NET AREA	3,341	DETAIL ADJ	1.000	FOUNDATION	4	FLR/WALL(FULL)	1.00	A	BIG	N	BUILT-IN GARAGE	552		97.48	53,807		
\$NLA(RCN)	\$232	OVERALL	1.190	EXT COVER	1	WOOD SHINGLE	1.02	+	USF	L	UPPER STORY FIN	1,415	2005	129.26	182,901		
				ROOF SHAPE	1	GABLE	1.00	+	BMU	N	BSMT UNFINISHED	1,926		36.87	71,002		
				ROOF COVER	1	ASPH/COMP SHIN	1.00	+	BAS	L	BASE AREA	1,926	2005	220.20	424,105		
				FLOOR COVER	1	HARDWOOD	1.02	C	OPA	N	OPEN PORCH	64		95.28	6,098		
				INT. FINISH	2	DRYWALL	1.00	F	WDK	N	WOOD DECK	110		49.13	5,404		
				HEATING/COOLING	10	HOT/COOL WATER	1.05	BMG	O	BSMT GARAGE	1			8,861.90	8,862		
				FUEL SOURCE	1	OIL	1.00	F21	O	FPL 2S 1OP	1			10,951.80	10,952		
				USE	0		1.00	FIX	O	XTRA FIXTURES	4			2,647.50	10,590		

CLASS	CLASS%	DESCRIPTION		BN ID	BN	CARD		
0170	100	Mixed-Res/Chpt			1	1 of 1		
PMT NO	PMT DT	TY	DESC	AMOUNT	INSP	BY	1st	%
12572	08/22/2012	3	ALT/RENO	2,398				
05170	03/23/2005	1	NEW CONSTRUC	135,000	09/15/2006	TL	100	100
05171	03/23/2005	1	NEW CONSTRUC	135,000	09/15/2006	TL	100	100

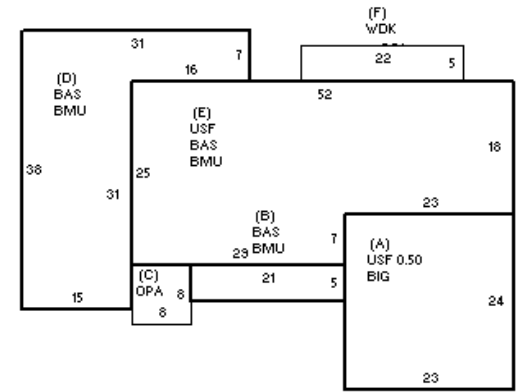

BLDG COMMENTS

CONDITION ELEM	CD
EXTERIOR	A
INTERIOR	A
KITCHEN	G
BATHS	G
HEAT	A
ELECT	A

EFF.YR/AGE	2010 / 12
COND	9 9 %
FUNC	0
ECON	0
DEPR	9 % GD 91

RCNLD	\$704,100
-------	-----------