

Key: 5232

Town of Bourne - Fiscal Year 2024

12/18/2023 6:02 pm SEQ #: 5.375

LEGAL

LAND

DETACHED

BUILDING

CURRENT OWNER		PARCEL ID		LOCATION	
BROWN D KEITH 3 ANNE LN BOURNE, MA 02532-3752		26.0-22-0		3 ANNE LN	
TRANSFER HISTORY		DOS	T	SALE PRICE	BK-PG (Cert)
BROWN D KEITH		11/04/2011	F	100	25814-133
BROWN D KEITH & MCCARTHY MARY C		11/30/1999	QS	270,000	12693-320
		04/14/1989	O	223,020	9558-80

CLASS	CLASS%	DESCRIPTION		BN ID	BN	CARD	
1010	100	SINGLE FAMILY			1	1 of 1	
PMT NO	PMT DT	TY	DESC	AMOUNT	INSP	BY	%
		3	ALT/RENO		04/05/2023	SL	100

CD	T	AC/SF/UN	Nbhd	Infl1	N Index	ADJ BASE	SAF	Topo	Lpi	VC	CREDIT AMT	ADJ VALUE
100	S	22,546 6	1.00	100	1.00	294,625	1.55	A	1.00	R07	1.25	236,260
300	A	0.039 6	1.00	100	1.00	20,375	1.00	OS	1.00	R07	1.25	790

TOTAL	22,546 SF	ZONING	1	FRNT	0	ASSESSED	CURRENT	PREVIOUS
Nbhd	BOURNE	NOTE 326=GREEN AREA ON PLAN 1/7 INT	LAND	237,100	209,800			
Infl1	AVG		BUILDING	386,100	325,700			
N_Index	AVG		DETACHED	0	0			
			OTHER	0	0			
			TOTAL	623,200	535,500			

TY	QUAL	COND	DIM/NOTE	YB	UNITS	ADJ PRICE	RCNLD

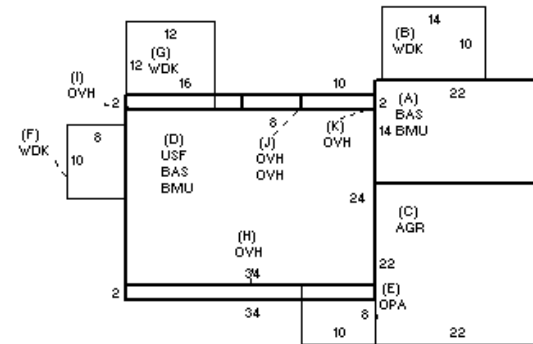

BUILDING	CD	ADJ	DESC	MEASURE	4/5/2023	SL
MODEL	1		RESIDENTIAL	LIST	4/5/2023	SL
STYLE	5	1.00	COLONIAL [100%]	REVIEW	4/5/2023	SL
QUALITY	+	1.05	AVERAGE + [100%]			
FRAME	1	1.00	WOOD FRAME [100%]			

BLDG COMMENTS

YEAR BLT	1989	SIZE ADJ	1.005
NET AREA	2,092	DETAIL ADJ	1.000
\$NLA(RCN)	\$234	OVERALL	1.070
CAPACITY		UNITS	ADJ
STORIES	2	1.00	
ROOMS	7	1.00	
BEDROOMS	3	1.00	
BATHROOMS	2	1.00	
FIXTURES	9	1.00	
GARAGE CAPACITY	2	1.00	
% BSMT FINISH	0	1.00	
# OF HALF BATHS	0	1.00	
# OF UNITS	1	1.00	

ELEMENT	CD	DESCRIPTION	ADJ	S	BAT	T	DESCRIPTION	UNITS	YB	ADJ PRICE	RCN
FOUNDATION	4	FLR/WALL(FULL)	1.00	+	BMU	N	BSMT UNFINISHED	1,124		41.17	46,279
EXT COVER	1	WOOD SHINGLE	1.02	+	BAS	L	BASE AREA	1,124	1989	216.75	243,630
ROOF SHAPE	1	GABLE	1.00	+	WDK	N	WOOD DECK	364		24.12	8,779
ROOF COVER	1	ASPH/COMP SHIN	1.00	C	AGR	N	ATT GARAGE	484		69.79	33,776
FLOOR COVER	31	WW-HARDWOOD	1.00	D	USF	L	UPPER STORY FIN	816	1989	121.55	99,185
INT. FINISH	2	DRYWALL	1.00	E	OPA	N	OPEN PORCH	80		81.14	6,491
HEATING/COOLING	11	HT WATER CL AIR	1.05	+	OVH	L	OVERHANG	152	1989	204.48	31,081
FUEL SOURCE	1	OIL	1.00		F21	O	FPL 2S 1OP	1		9,946.40	9,946
USE	0		1.00		FIX	O	XTRA FIXTURES	4		2,404.45	9,618

TOTAL RCN	488,786
CONDITION ELEM	CD
EXTERIOR	A
INTERIOR	A
KITCHEN	A
BATHS	A
HEAT	A
ELECT	A
EFF.YR/AGE	1998 / 24
COND	21 21 %
FUNC	0
ECON	0
DEPR	21 % GD 79
RCNLD	\$386,100