

Key: 5321

Town of Bourne - Fiscal Year 2024

12/18/2023 6:02 pm SEQ #: 5.463

LEGAL

| CURRENT OWNER | | | | PARCEL ID | | | | LOCATION | | | |
|---|--|--|--|------------|----|------------|--------------|--------------|--|--|--|
| Dwyer Daniel & Roberta Trs Dwyer Revocable Trust 65 Gilder Rd Bourne, MA 02532 | | | | 26.1-95-0 | | | | 65 GILDER RD | | | |
| TRANSFER HISTORY | | | | DOS | T | SALE PRICE | BK-PG (Cert) | | | | |
| Dwyer Daniel & Roberta Tr | | | | 07/14/2022 | F | | 1 | 35248-84 | | | |
| Dwyer Daniel A Etux | | | | 10/05/2007 | QS | 1,303,500 | | 22388-292 | | | |
| Ethier Richard R & | | | | 02/08/2005 | QS | 1,000,000 | | 19513-66 | | | |

| CLASS | CLASS% | DESCRIPTION | | | BN ID | BN | CARD |
|--------|--------|---------------|------|--------|-------|----|--------|
| 1010 | 100 | SINGLE FAMILY | | | | 1 | 1 of 1 |
| PMT NO | PMT DT | TY | DESC | AMOUNT | INSP | BY | 1st % |
| | | | | | | | |

LAND

| CD | T | AC/SF/UN | Nbhd | Infl1 | N Index | ADJ BASE | SAF | Topo | Lpi | VC | CREDIT AMT | ADJ VALUE |
|-----|---|----------|------|----------|----------|----------|------|------|------|-----|------------|-----------|
| 100 | S | 16,300 7 | | 1.00 100 | 1.00 100 | 848,520 | 2.03 | A | 1.00 | CEX | 3.60 | 645,120 |

| | | | | | | | | |
|---------|-----------|--------|----------|---------|---------|----------|-----------|-----------|
| TOTAL | 16,291 SF | ZONING | 1 | FRNT | 0 | ASSESSED | CURRENT | PREVIOUS |
| Nbhd | GRAY GAB | NOTE | | | | LAND | 645,100 | 571,000 |
| Infl1 | AVG | | BUILDING | 596,500 | 527,800 | | | |
| N_Index | AVG | | DETACHED | 0 | 0 | | | |
| | | | OTHER | 0 | 0 | | | |
| | | | | | | TOTAL | 1,241,600 | 1,098,800 |

DETACHED

| TY | QUAL | COND | DIM/NOTE | YB | UNITS | ADJ PRICE | RCNLD |
|----|------|------|----------|----|-------|-----------|-------|
| | | | | | | | |

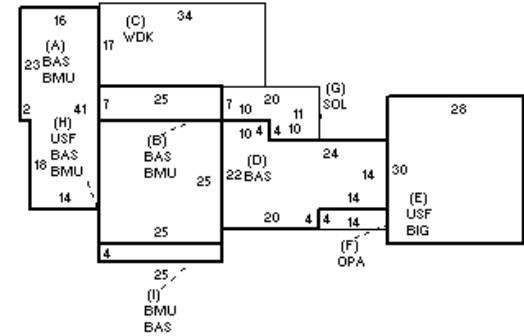

BUILDING

| BUILDING | CD | ADJ | DESC | MEASURE | 7/23/2001 | TL |
|----------|----|------|---------------------|---------|-----------|----|
| MODEL | 1 | | RESIDENTIAL | LIST | 7/23/2001 | TL |
| STYLE | 7 | 1.00 | CONVENTIONAL [100%] | REVIEW | 6/26/2008 | DB |
| QUALITY | + | 1.05 | AVERAGE + [100%] | | | |
| FRAME | 1 | 1.00 | WOOD FRAME [100%] | | | |

| BLDG COMMENTS |
|---------------|
| |

G

| YEAR BLT | 1932 | SIZE ADJ | 0.990 | ELEMENT | CD | DESCRIPTION | ADJ | S | BAT | T | DESCRIPTION | UNITS | YB | ADJ PRICE | RCN | TOTAL RCN | 764,702 | | |
|------------|-------|------------|-------|-----------------|----|----------------|------|-----|-----|---------------|-----------------|-------|----------|-----------|---------|-----------|---------|------------|------------|
| NET AREA | 3,581 | DETAIL ADJ | 1.000 | FOUNDATION | 4 | FLR/WALL(FULL) | 1.00 | + | BMU | N | BSMT UNFINISHED | 1,520 | | 35.20 | 53,506 | | | | |
| \$NLA(RCN) | \$214 | OVERALL | 1.060 | EXT COVER | 1 | WOOD SHINGLE | 1.02 | C | WDK | N | WOOD DECK | 578 | | 23.54 | 13,604 | | | | |
| | | | | ROOF SHAPE | 3 | GAMBREL | 1.00 | + | BAS | L | BASE AREA | 2,116 | 1932 | 189.37 | 400,711 | | | | |
| | | | | ROOF COVER | 1 | ASPH/COMP SHIN | 1.00 | E | BIG | N | BUILT-IN GARAGE | 840 | | 77.12 | 64,783 | | | | |
| | | | | FLOOR COVER | 1 | HARDWOOD | 1.02 | + | USF | L | UPPER STORY FIN | 1,465 | 1932 | 114.56 | 167,829 | | | | |
| | | | | INT. FINISH | 2 | DRYWALL | 1.00 | F | OPA | N | OPEN PORCH | 56 | | 84.45 | 4,729 | | | | |
| | | | | HEATING/COOLING | 2 | HOT WATER | 1.02 | G | SOL | N | SOLARIUM | 180 | | 105.61 | 19,010 | | | | |
| | | | | FUEL SOURCE | 2 | GAS | 1.00 | F21 | O | FPL 2S 1OP | 2 | | 9,706.35 | 19,413 | | | | | |
| | | | | USE | 0 | | 1.00 | FIX | O | XTRA FIXTURES | 9 | | 2,346.49 | 21,118 | | | | | |
| | | | | | | | | | | | | | | | | | | EFF.YR/AGE | 1997 / 25 |
| | | | | | | | | | | | | | | | | | | COND | 22 22 % |
| | | | | | | | | | | | | | | | | | | FUNC | 0 |
| | | | | | | | | | | | | | | | | | | ECON | 0 |
| | | | | | | | | | | | | | | | | | | DEPR | 22 % GD 78 |
| | | | | | | | | | | | | | | | | | | RCNLD | \$596,500 |