

Key: 5328

Town of Bourne - Fiscal Year 2024

12/18/2023 6:02 pm SEQ #: 5.471

LEGALS

CURRENT OWNER				PARCEL ID				LOCATION			
SCHROTH LAURA E 45 PRESIDENTS ROAD BOURNE, MA 02532				26.1-101-0				45 PRESIDENTS RD			
TRANSFER HISTORY				DOS	T	SALE PRICE	BK-PG (Cert)				
SCHROTH LAURA E				07/24/2019	QS	408,500	()				
PIERSON ROBIN E				06/15/2000	QS	189,000	()				
CARNEVALI GIUSEPPE				09/22/1993	QS	119,500	8792-029				

CLASS	CLASS%	DESCRIPTION			BN ID	BN	CARD	
1010	100	SINGLE FAMILY				1	1 of 1	
PMT NO	PMT DT	TY	DESC	AMOUNT	INSP	BY	1st	%
19885	09/23/2019	15	INSULATE/WEA	1,594			100	100
12192	03/27/2012	3	ALT/RENO	2,500	01/10/2013	TL	100	100
12077	02/09/2012	6	FENCE	2,475	01/10/2013	TL	100	100
11176	04/14/2011	2	ADDITIONS	34,500	01/10/2013	TL	100	100
11002	01/05/2011	15	INSULATE/WEA	2,808	01/10/2013	TL	100	100

LAND

CD	T	AC/SF/UN	Nbhd	Infl1	N Index	ADJ BASE	SAF	Topo	Lpi	VC	CREDIT AMT	ADJ VALUE						
100	S	19,516	7	1.00	100	1.00	1.00	1.00	424,260	1.74	A	1.00	BGD	1.80				331,650

TOTAL	19,515 SF	ZONING	1	FRNT	0	ASSESSED	CURRENT	PREVIOUS
Nbhd	GRAY GAB	NOTE ash = Reflections by Robin workshop	LAND	331,700	293,500			
Infl1	AVG		BUILDING	284,800	255,000			
N_Index	AVG		DETACHED	0	0			
			OTHER	0	0			
<b>TOTAL</b>				<b>616,500</b>	<b>548,500</b>			

DETACHED

TY	QUAL	COND	DIM/NOTE	YB	UNITS	ADJ PRICE	RCNLD	PHOTO	01/12/2013
SHF	A	1.00	A 0.75 6 X 8			0.00			

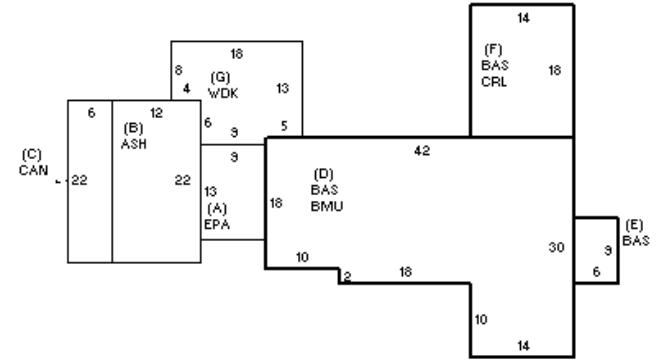

BUILDING	CD	ADJ	DESC	MEASURE	10/5/2015	TL
MODEL	1		RESIDENTIAL	LIST	10/5/2015	TL
STYLE	1	0.95	RANCH [100%]	REVIEW		
QUALITY	+	1.05	AVERAGE + [100%]			
FRAME	1	1.00	WOOD FRAME [100%]			

BLDG COMMENTS

BUILDING

YEAR BLT	1947	SIZE ADJ	1.015	ELEMENT	CD	DESCRIPTION	ADJ	S	BAT	T	DESCRIPTION	UNITS	YB	ADJ PRICE	RCN	TOTAL RCN	343,081
NET AREA	1,266	DETAIL ADJ	1.000	FOUNDATION	4	FLR/WALL(FULL)	1.00	A	EPA	N	ENCLOSED PORCH	117		88.55	10,360		
\$NLA(RCN)	\$271	OVERALL	1.010	EXT COVER	1	WOOD SHINGLE	1.02	B	ASH	N	ATT SHED	264		23.15	6,111		
				ROOF SHAPE	1	GABLE	1.00	C	CAN	N	CANOPY	132		13.21	1,744		
				ROOF COVER	1	ASPH/COMP SHIN	1.00	D	BMU	N	BSMT UNFINISHED	960		39.25	37,681		
				FLOOR COVER	2	SOFTWOOD	1.02	+	BAS	L	BASE AREA	1,014	1947	202.35	205,178		
				INT. FINISH	2	DRYWALL	1.00	F	CRL	N	BSMT CRAWL	252		36.88	9,293		
				HEATING/COOLING	2	HOT WATER	1.02	F	BAS	L	BASE AREA	252	2011	202.34	50,991		
				FUEL SOURCE	1	OIL	1.00	G	WDK	N	WOOD DECK	223		27.88	6,216		
				USE	0		1.00	F11	O		FPL 1S 1OP	1		8,630.60	8,631		
								FIX	O		XTRA FIXTURES	3		2,292.40	6,877		

CONDITION ELEM	CD
EXTERIOR	A
INTERIOR	A
KITCHEN	G
BATHS	G
HEAT	A
ELECT	A

EFF.YR/AGE	2002 / 20
COND	17 17 %
FUNC	0
ECON	0
DEPR	17 % GD 83

RCNLD	\$284,800
-------	-----------