

Key: 5424

Town of Bourne - Fiscal Year 2024

12/18/2023 6:02 pm SEQ #: 5.571

LEGAL

Table with columns: CURRENT OWNER, PARCEL ID, LOCATION, TRANSFER HISTORY, DOS, T, SALE PRICE, BK-PG (Cert). Includes owner name Spencer William I & Laura J Spencer and parcel details.

Table with columns: CLASS, CLASS%, DESCRIPTION, BN ID, BN, CARD. Includes class 1010 and description SINGLE FAMILY.

LAND

Table with columns: CD, T, AC/SF/UN, Nbhd, Infl1, N Index, ADJ BASE, SAF, Topo, Lpi, VC, CREDIT AMT, ADJ VALUE. Includes land area and value information.

Table with columns: TOTAL, ZONING, FRNT, ASSESSED, CURRENT, PREVIOUS. Includes zoning 1 and assessed value 744,100.

DETACHED

Table with columns: TY, QUAL, COND, DIM/NOTE, YB, UNITS, ADJ PRICE, RCNLD. Includes quality and condition details.

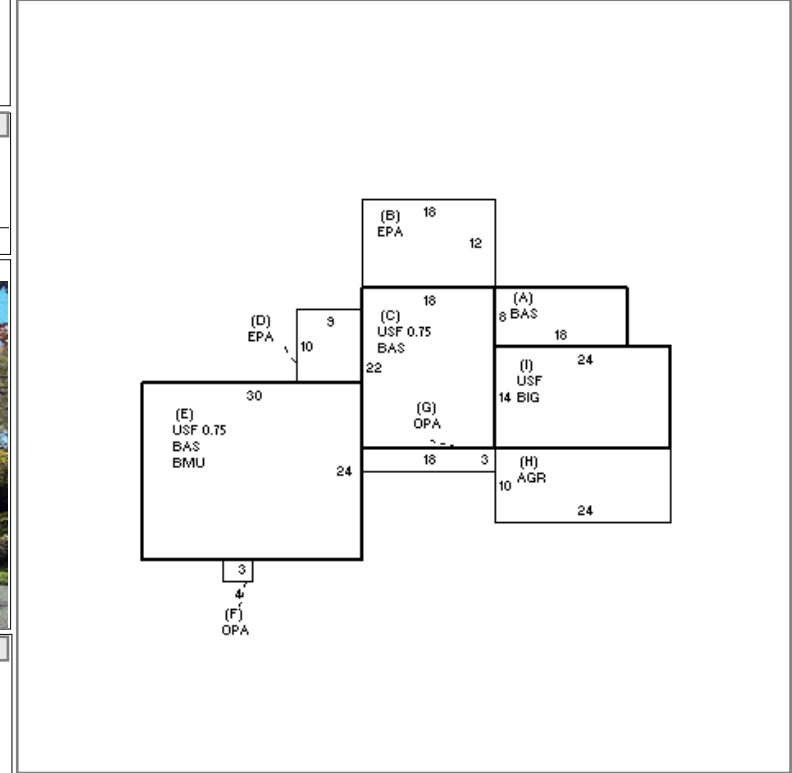

BUILDING

Table with columns: BUILDING, CD, ADJ, DESC, MEASURE, 1/11/2006, TL. Includes building details like residential style and wood frame.

Table with columns: BLDG COMMENTS. Currently empty.

G

Main summary table with columns: YEAR BLT, SIZE ADJ, ELEMENT, CD, DESCRIPTION, ADJ, S, BAT, T, DESCRIPTION, UNITS, YB, ADJ PRICE, RCN, TOTAL RCN, CONDITION ELEM, CD. Includes building statistics and detailed room breakdown.