

Key: 5500

Town of Bourne - Fiscal Year 2024

12/18/2023 6:02 pm SEQ #: 5.642

LEGAL

LAND

DETAILED

BUILDING

CURRENT OWNER				PARCEL ID				LOCATION			
KRAUNELIS ANTHONY F JR & MEGHAN E KRAUNELIS 2 BELL RD EXT BOURNE, MA 02532				26.2-81-0				226 SHORE RD			
TRANSFER HISTORY				DOS	T	SALE PRICE	BK-PG (Cert)				
KRAUNELIS ANTHONY F JR & POCASSET BACK RIVER LLC				08/21/2020	O	350,000	33187-161				
FALLON JEFFREY W				05/26/2016	L	253,000	29678-219				
				03/05/2013	F	1	27183-270				

CLASS	CLASS%	DESCRIPTION		BN ID	BN	CARD	
1010	100	SINGLE FAMILY			1	1 of 1	
PMT NO	PMT DT	TY	DESC	AMOUNT	INSP	BY	1st %
B-22-23	03/02/2022	3	ALT/RENO		02/09/2023	TL	100 100
B-21-235	07/20/2021	3	ALT/RENO		02/06/2023	SL	100 100
		2	ADDITIONS	20,000	04/07/2022	TL	100 100
		2	ADDITIONS		02/06/2023	SL	100 100
		8	POOL	31,500	02/06/2023	SL	100 100

CD	T	AC/SF/UN	Nbhd	Infl1	N Index	ADJ BASE	SAF	Topo	Lpi	VC	CREDIT AMT	ADJ VALUE				
100	S	40,000	6	1.00	100	1.00	100	1.00	294,625	1.00	A	1.00	R07	1.25		270,490
300	A	0.582	6	1.00	100	1.00	100	1.00	20,375	1.00	A	1.00	R07	1.25		11,860

TOTAL	1.500 Acres	ZONING	1	FRNT	0	ASSESSED	CURRENT	PREVIOUS
Nbhd	BOURNE	NOTE	LAND		282,400	249,900		
Infl1	AVG		BUILDING		458,600	278,300		
N_Index	AVG		DETACHED		29,100	19,800		
		OTHER		0	0			
		TOTAL		770,100	548,000			

TY	QUAL	COND	DIM/NOTE	YB	UNITS	ADJ PRICE	RCNLD
SHF	A	1.00	80 0.20			0.00	
SHF	A	1.00	80 0.20			0.00	
IPG	V	1.30	10 0.90			38.63	17,800
PTD	V	1.30	10 0.90	2021	512	4.58	7,800
PBD	V	1.30	10 0.90	2022	144	26.65	3,500



BUILDING	CD	ADJ	DESC	MEASURE	2/6/2023	SL
MODEL	1		RESIDENTIAL	LIST	3/8/2023	SL
STYLE	1	0.95	RANCH [100%]	REVIEW	3/8/2023	TL
QUALITY	A	1.00	AVERAGE [100%]			
FRAME	1	1.00	WOOD FRAME [100%]			

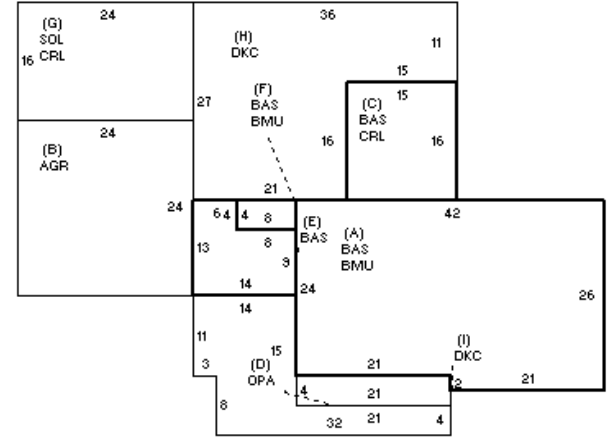

BLDG COMMENTS

YEAR BLT	1968	SIZE ADJ	1.015	ELEMENT	CD	DESCRIPTION	ADJ	S	BAT	T	DESCRIPTION	UNITS	YB	ADJ PRICE	RCN	TOTAL RCN	498,445		
NET AREA	1,472	DETAIL ADJ	1.000	FOUNDATION	4	FLR/WALL(FULL)	1.00	+	BMU	N	BSMT UNFINISHED	1,082		37.75	40,848	CONDITION ELEM	CD		
\$NLA(RCN)	\$339	OVERALL	1.020	EXT COVER	1	WOOD SHINGLE	1.02	B	AGR	N	ATT GARAGE	576		63.99	36,857	EXTERIOR	G		
				ROOF SHAPE	1	GABLE	1.00	+	CRL	N	BSMT CRAWL	624		26.60	16,596	INTERIOR	G		
				ROOF COVER	1	ASPH/COMP SHIN	1.00	D	OPA	N	OPEN PORCH	84		74.41	6,250	KITCHEN	G		
				FLOOR COVER	1	HARDWOOD	1.02	+	BAS	L	BASE AREA	1,472	1968	189.93	279,578	BATHS	G		
				INT. FINISH	1	PLASTER	1.00	G	SOL	N	SOLARIUM	384		89.28	34,285	HEAT	U		
				HEATING/COOLING	9	WARM-COOL AIR	1.03	+	DKC	N	DECK-COMPOSITE	1,058		61.42	64,985	ELECT	U		
				FUEL SOURCE	1	OIL	1.00	F11	O	FPL 1S 1OP	1		8,301.00	8,301					
				USE	0		1.00	FIX	O	XTRA FIXTURES	3		2,204.83	6,615					
								MST	O	MAS/METAL STACK	1		4,131.90	4,132					
																		EFF.YR/AGE	2011 / 11
																		COND	8 8 %
																		FUNC	0 uc
																		ECON	0
																		DEPR	8 % GD 92
																		RCNLD	\$458,600