

Key: 5594

Town of Bourne - Fiscal Year 2024

12/18/2023 6:02 pm SEQ #: 5.735

LEGALS

CURRENT OWNER		PARCEL ID	LOCATION				
STROJNY STEVEN M & LYNNE M PRINCIGALLI 12 WARREN RD BOURNE, MA 02532-3535		26.3-35-1	12 WARREN RD				
		TRANSFER HISTORY		DOS	T	SALE PRICE	BK-PG (Cert)
		STROJNY STEVEN M & TER MEULEN ADRIAAN W & JENKINS PATRICK		10/19/2000	QS	650,000	13307-131
			01/07/1999	QS	370,000	11974-184	
			05/09/1985	QS	65,000	04524-00012	

CLASS	CLASS%	DESCRIPTION		BN ID	BN	CARD	
1010	100	SINGLE FAMILY			1	1 of 1	
PMT NO	PMT DT	TY	DESC	AMOUNT	INSP	BY	1st %
960095	03/28/1996	3	ALT/RENO	4,000	07/02/1997	JC	100 100
950139	03/31/1995	3	ALT/RENO	1,500	10/29/1996	JC	100 100

LAND

CD	T	AC/SF/UN	Nbhd	Infl1	N Index	ADJ BASE	SAF	Topo	Lpi	VC	CREDIT AMT	ADJ VALUE				
100	S	14,200	7	1.00	100	1.00	100	1.00	707,100	2.29	A	1.00	BEX	3.00		527,720

TOTAL	14,201 SF	ZONING	1	FRNT	0	ASSESSED	CURRENT	PREVIOUS
Nbhd	GRAY GAB	NOTE				LAND	527,700	467,000
Infl1	AVG		LAND	460,800	407,800			
N_Index	AVG		BUILDING	0	0			
			OTHER	0	0			
			TOTAL	988,500	874,800			

DETACHED

TY	QUAL	COND	DIM/NOTE	YB	UNITS	ADJ PRICE	RCNLD	PHOTO	11/10/2003
									

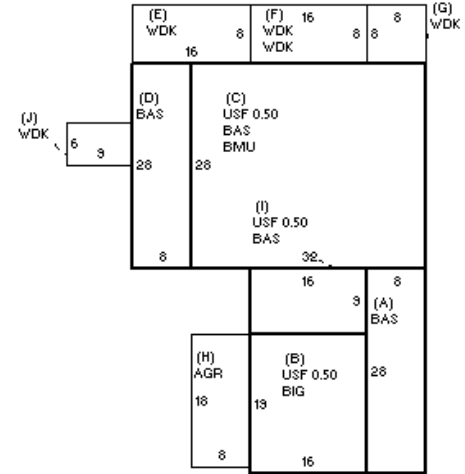

BUILDING

BUILDING	CD	ADJ	DESC	MEASURE	2/4/2022	RP
MODEL	1		RESIDENTIAL	LIST	2/4/2022	EST
STYLE	4	1.05	CAPE [100%]	REVIEW	2/4/2022	RP
QUALITY	G	1.10	GOOD [100%]			
FRAME	1	1.00	WOOD FRAME [100%]			

YEAR BLT	1986	SIZE ADJ	1.005	ELEMENT	CD	DESCRIPTION	ADJ	S	BAT	T	DESCRIPTION	UNITS	YB	ADJ PRICE	RCN
NET AREA	2,160	DETAIL ADJ	1.000	FOUNDATION	4	FLR/WALL(FULL)	1.00	+	BAS	L	BASE AREA	1,488	1986	221.06	328,940
\$NLA(RCN)	\$274	OVERALL	1.090	EXT COVER	2	CLAPBOARD	1.00	B	BIG	N	BUILT-IN GARAGE	304		106.69	32,435
				ROOF SHAPE	1	GABLE	1.00	+	USF	L	UPPER STORY FIN	672	1986	131.02	88,048
				ROOF COVER	1	ASPH/COMP SHIN	1.00	C	BMU	N	BSMT UNFINISHED	896		43.94	39,371
				FLOOR COVER	1	HARDWOOD	1.02	+	WDK	N	WOOD DECK	502		25.74	12,921
				INT. FINISH	2	DRYWALL	1.00	H	AGR	N	ATT GARAGE	144		103.30	14,875
				HEATING/COOLING	2	HOT WATER	1.02	BGF	N	BSMT GOOD FINIS	896		53.77	48,182	
				FUEL SOURCE	2	GAS	1.00	F21	O	FPL 2S 1OP	1		10,614.80	10,615	
				USE	0		1.00	FIX	O	XTRA FIXTURES	6		2,566.23	15,397	

TOTAL RCN	590,783
CONDITION ELEM CD	
EXTERIOR	A
INTERIOR	A
KITCHEN	A
BATHS	A
HEAT	A
ELECT	A
EFF.YR/AGE 1997 / 25	
COND	22 22 %
FUNC	0
ECON	0
DEPR	22 % GD 78
RCNLD	\$460,800