

Key: 5616

Town of Bourne - Fiscal Year 2024

12/18/2023 6:02 pm SEQ #: 5758

LEGALS

LAND

DETACHED

BUILDING

CURRENT OWNER				PARCEL ID				LOCATION			
22 SPINDRIFT LANE LLC c/o DEBRA MOSEL UNIT 6100, BOX 054 DPO, AE 09802-054				26.3-52-0				22 SPINDRIFT LN			
TRANSFER HISTORY				DOS	T	SALE PRICE	BK-PG (Cert)				
22 SPINDRIFT LANE LLC				06/27/2014	F		10 28231-170				
MOSEL DEBRA				06/18/2010	F		N/A-N/A				
ESTATE OF JOSEPH E MOSEL				12/18/2007	F		22546-117				

CLASS	CLASS%	DESCRIPTION			BN ID	BN	CARD	
1010	100	SINGLE FAMILY				1	1 of 1	
PMT NO	PMT DT	TY	DESC	AMOUNT	INSP	BY	1st	%

CD	T	AC/SF/UN	Nbhd	Infl1	N Index	ADJ BASE	SAF	Topo	Lpi	VC	CREDIT AMT	ADJ VALUE
100	S	12,600 7	1.00	100	1.00	1,225,640	2.54	A	1.00	BSP	5.20	901,660

TOTAL	12,589 SF	ZONING	1	FRNT	0	ASSESSED	CURRENT	PREVIOUS
Nbhd	GRAY GAB	NOTE				LAND	901,700	798,000
Infl1	AVG		BUILDING	176,100	155,900			
N_Index	AVG		DETACHED	14,700	14,100			
			OTHER	0	0			
						TOTAL	1,092,500	968,000

TY	QUAL	COND	DIM/NOTE	YB	UNITS	ADJ PRICE	RCNLD
WDK	A	1.00	A 0.75 11 X 22		242	18.30	3,300
IPG	A	1.00	A 0.75 16 X 32		512	29.72	11,400
SHM	F	0.70	F 0.60 9 X 10			0.00	

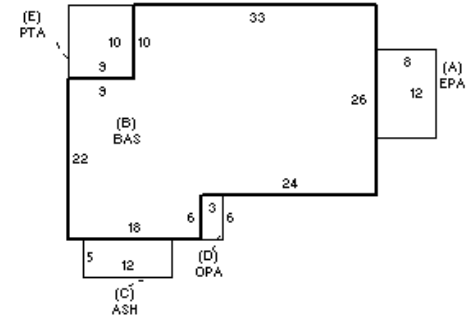

BUILDING	CD	ADJ	DESC	MEASURE	5/9/2008	TL
MODEL	1		RESIDENTIAL	LIST	9/15/2008	TL
STYLE	1	0.95	RANCH [100%]	REVIEW	10/31/2016	DB
QUALITY	A	1.00	AVERAGE [100%]			
FRAME	1	1.00	WOOD FRAME [100%]			

BLDG COMMENTS

YEAR BLT	1954	SIZE ADJ	1.015
NET AREA	1,110	DETAIL ADJ	1.000
\$NLA(RCN)	\$214	OVERALL	0.980
CAPACITY		UNITS	ADJ
STORIES	1	1.00	
ROOMS	4	1.00	
BEDROOMS	2	1.00	
BATHROOMS	1	1.00	
FIXTURES	6	1.00	
GARAGE CAPACITY	0	1.00	
% BSMT FINISH	0	1.00	
# OF HALF BATHS	0	1.00	
# OF UNITS	1	1.00	

ELEMENT	CD	DESCRIPTION	ADJ	S	BAT	T	DESCRIPTION	UNITS	YB	ADJ PRICE	RCN
FOUNDATION	4	FLR/WALL(FULL)	1.00	A	EPA	N	ENCLOSED PORCH	96		81.01	7,777
EXT COVER	1	WOOD SHINGLE	1.02	B	BAS	L	BASE AREA	1,110	1954	190.95	211,953
ROOF SHAPE	1	GABLE	1.00	C	ASH	N	ATT SHED	60		23.72	1,423
ROOF COVER	1	ASPH/COMP SHIN	1.00	D	OPA	N	OPEN PORCH	18		94.55	1,702
FLOOR COVER	3	W/W CARPET	1.00	E	PTA	N	PATIO	90		14.48	1,303
INT. FINISH	3	WOOD PANEL	0.98		CPC	O	CAPE CELLAR	1		3,756.00	3,756
HEATING/COOLING	9	WARM-COOL AIR	1.03	F11	O	FPL 1S 1OP		1		7,975.50	7,976
FUEL SOURCE	2	GAS	1.00	FIX	O	XTRA FIXTURES		1		2,118.70	2,119
USE	0		1.00								

TOTAL RCN	238,008
CONDITION ELEM	CD
EXTERIOR	A
INTERIOR	F
KITCHEN	A
BATHS	A
HEAT	A
ELECT	A
EFF.YR/AGE	1993 / 29
COND	26 26 %
FUNC	0
ECON	0
DEPR	26 % GD 74
RCNLD	\$176,100