

Key: 5849

Town of Bourne - Fiscal Year 2024

12/18/2023 6:02 pm SEQ #: 6.007

LEGAL

CURRENT OWNER						PARCEL ID				LOCATION			
BALE TODD & CINZIA BALE 5 HOLLY CIRCLE BUZZARDS BAY, MA 02532						27.0-101-2				5 HOLLY CIR			
TRANSFER HISTORY						DOS	T	SALE PRICE	BK-PG (Cert)				
BALE TODD & CINZIA BALE						10/06/2017	QS	239,000	(C79-12B)				
BARTOLOMEI MARVIN						10/06/2017	F		(C79-12B)				
BARTOLOMEI MARVIN E ETUX						09/28/2010	QS	177,500	(C79-12B)				

CLASS	CLASS%	DESCRIPTION			BN ID	BN	CARD	
1020	100	CONDOMINIUM				1	1 of 1	
PMT NO	PMT DT	TY	DESC	AMOUNT	INSP	BY	1st	%
EXB-22-713	10/25/2022	3	ALT/RENO	7,931			100	100
17864	10/19/2017	3	ALT/RENO	12,000	05/10/2018	BC	100	100
13214	04/08/2013	6	FENCE	1,600	04/08/2013		100	100

LAND

CD	T	AC/SF/UN	Nbhd	Infl1	N Index	ADJ BASE	SAF	Topo	Lpi	VC	CREDIT AMT	ADJ VALUE

TOTAL	31,363 SF	ZONING	FRNT	0	ASSESSED	CURRENT	PREVIOUS
Nbhd		NOTE mailed sales ver 6/27/11	LAND	0	0	0	
Infl1			BUILDING	316,900	280,400		
N_Index			DETACHED	500	500		
			OTHER	0	0		
			TOTAL	317,400	280,900		

DETACHED

TY	QUAL	COND	DIM/NOTE	YB	UNITS	ADJ PRICE	RCNLD
W05	L	0.90 10 0.90	100'		100	5.58	500

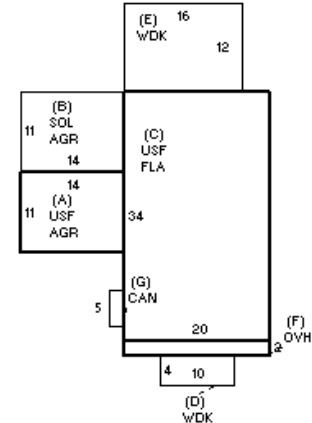

BUILDING

BUILDING	CD	ADJ	DESC	MEASURE	5/10/2018	BC
MODEL	10		RES CONDO	LIST	5/10/2018	BC
STYLE	1	1.35	TOWN HOUSE END [100%]	REVIEW	7/11/2018	DB
QUALITY	A	1.00	AVERAGE [100%]			
FRAME	1	1.00	WOOD FRAME [100%]			

BLDG COMMENTS

LOADING

YEAR BLT	1981	SIZE ADJ	1.000	ELEMENT	CD	DESCRIPTION	ADJ	S	BAT	T	DESCRIPTION	UNITS	YB	ADJ PRICE	RCN	TOTAL RCN	356,045
NET AREA	1,554	DETAIL ADJ	1.000	COMPLEX	10	TRADE WINDS	1.05	+	AGR	N	ATTACHED GARAGE	308		46.06	14,186	CONDITION ELEM	CD
\$NLA(RCN)	\$229	OVERALL	1.400	OCCUPANCY	1	YEAR ROUND	1.00	+	USF	L	UPPER STORY FIN	834	1981	121.94	101,697	INTERIOR	A
CAPACITY			UNITS	ADJ	FLOOR/LOC	5	1.00	B	SOL	N	SOLARIUM	154		65.66	10,112	KITCHEN	G
ROOMS	4	1.00	VIEW INFL	5	AVERAGE	1.00	1.00	C	FLA	L	LIVING AREA	680	1981	322.69	219,432	BATHS	A
BEDROOMS	2	1.00	HT/CL	1	FORCED AIR	1.00	1.00	+	WDK	N	WOODDECK	232		25.20	5,846	EXTERIOR	A
BATHROOMS	2	1.00	WDK/PTA/BALC	1	PRESENT	1.00	1.00	F	OVH	L	OVER HANG	40	1981	112.98	4,519		
HALFBATHS	1	1.00	PARKING	3	GARAGE 1 SPACE	1.00	1.00	G	CAN	N	CANOPY	10		25.20	252		
FIREPLACES	0	1.00	NET ADJ(%GOOD)	100	100 %RG	1.00	1.00										
EFF.YR/AGE 1986 / 36																	
COND 11 11 %																	
FUNC 0																	
ECON 0																	
DEPR 11 % GD 89																	
RCNLD \$316,900																	