

Key: 6134

Town of Bourne - Fiscal Year 2024

12/18/2023 6:02 pm SEQ #: 6.291

LEGAL

CURRENT OWNER				PARCEL ID				LOCATION			
HISS ROBERT G & MARY E RIFFE 273 ADAMS STREET MILTON, MA 02186				30.2-7-0				1 QUIET COVE LN			
TRANSFER HISTORY				DOS	T	SALE PRICE	BK-PG (Cert)				
				11/12/2019	V XX	675,000	32458-212 05154-00257				

CLASS	CLASS%	DESCRIPTION			BN ID	BN	CARD	
1010	100	SINGLE FAMILY				1	1 of 1	
PMT NO	PMT DT	TY	DESC	AMOUNT	INSP	BY	1st	%
10400	07/06/2010	4	DETACH.STRUC		11/22/2010		100	100

LAND

CD	T	AC/SF/UN	Nbhd	Infl1	N Index	ADJ BASE	SAF	Topo	Lpi	VC	CREDIT AMT	ADJ VALUE
100	S	20,130	9	1.00	100	1,508,480	1.70	A	1.00	BSP	6.40	1,185,350
300	A	0.032	9	1.00	100	104,320	1.00	A	1.00	BSP	6.40	3,340

TOTAL	21,519 SF	ZONING	1	FRNT	0	ASSESSED	CURRENT	PREVIOUS
Nbhd	MO BCH	NOTE sandy beach	LAND	1,188,700	1,052,000			
Infl1	AVG		BUILDING	324,900	291,600			
N_Index	AVG		DETACHED	1,900	1,800			
			OTHER	0	0			
			<b>TOTAL</b>	<b>1,515,500</b>	<b>1,345,400</b>			

DETACHED

TY	QUAL	COND	DIM/NOTE	YB	UNITS	ADJ PRICE	RCNLD
SHF	G	1.20 30 0.70	10 X 14		140	19.71	1,900

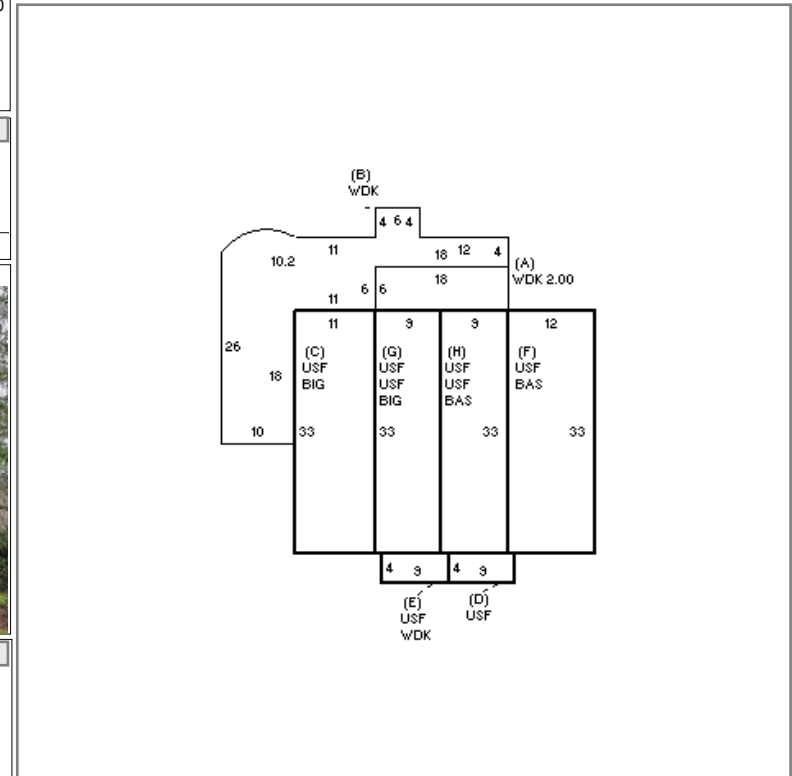

BU

BUILDING	CD	ADJ	DESC	MEASURE	9/3/2020	RP
MODEL	1		RESIDENTIAL	LIST	9/3/2020	EST
STYLE	8	1.10	CONTEMPORARY [100%]	REVIEW	9/3/2020	RP
QUALITY	+	1.05	AVERAGE + [100%]			
FRAME	1	1.00	WOOD FRAME [100%]			

BUILDING

YEAR BLT	1981	SIZE ADJ	1.000	ELEMENT	CD	DESCRIPTION	ADJ	S	BAT	T	DESCRIPTION	UNITS	YB	ADJ PRICE	RCN	TOTAL RCN	457.667	
NET AREA	2,712	DETAIL ADJ	1.000	FOUNDATION	2	SLAB	0.95	+	WDK	N	WOOD DECK	742		24.00	17,806	CONDITION ELEM	CD	
\$NLA(RCN)	\$169	OVERALL	1.070	EXT COVER	4	VINYL	1.00	C	BIG	N	BUILT-IN GARAGE	363		99.48	36,110	EXTERIOR	A	
				ROOF SHAPE	2	HIP	1.02	+	USF	L	UPPER STORY FIN	2,019	1981	97.34	196,529	INTERIOR	F	
				ROOF COVER	1	ASPH/COMP SHIN	1.00	+	BAS	L	BASE AREA	693	1981	231.75	160,601	KITCHEN	F	
				FLOOR COVER	3	W/W CARPET	1.00	G	BIG	N	BUILT-IN GARAGE	297		99.48	29,545	BATHS	F	
				INT. FINISH	2	DRYWALL	1.00		F21	O	FPL 2S 1OP	1		9,896.90	9,897	HEAT	A	
				HEATING/COOLING	1	FORCED AIR	1.00		FIX	O	XTRA FIXTURES	3		2,392.67	7,178	ELECT	A	
				FUEL SOURCE	2	GAS	1.00											
				USE	0		1.00											
																EFF.YR/AGE	1990 / 32	
																COND	29 29 %	
																FUNC	0	
																ECON	0	
																DEPR	29 % GD 71	
																RCNLD	\$324,900	