

Key: 615

Town of Bourne - Fiscal Year 2024

12/18/2023 6:02 pm SEQ #: 614

LEGALS

Table with columns: CURRENT OWNER, PARCEL ID, LOCATION, TRANSFER HISTORY, DOS, T, SALE PRICE, BK-PG (Cert). Includes owner name CURTIN JAMES J JR & BONNIE and parcel details for 26 LAKEWOOD RD.

Table with columns: CLASS, CLASS%, DESCRIPTION, BN ID, BN, CARD. Includes payment history with PMT NO, PMT DT, TY, DESC, AMOUNT, INSP, BY, 1st, %.

LAND

Table with columns: CD, T, AC/SF/UN, Nbhd, Infl1, N Index, ADJ BASE, SAF, Topo, Lpi, VC, CREDIT AMT, ADJ VALUE. Includes summary rows for TOTAL and ASSESSED values.

DETACHED

Table with columns: TY, QUAL, COND, DIM/NOTE, YB, UNITS, ADJ PRICE, RCNLD. Includes a photo of the property and a photo date of 11/21/2017.

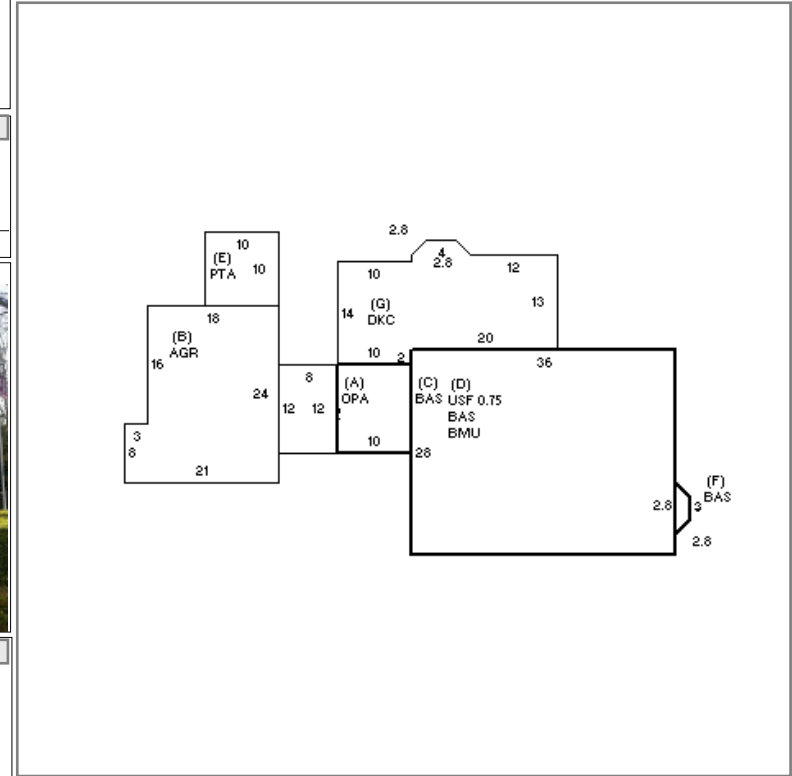

BUILDING

Table with columns: BUILDING, CD, ADJ, DESC, MEASURE, 7/20/2021, NMP. Includes details for RESIDENTIAL building type and quality.

Table with columns: BLDG COMMENTS. Currently empty.

INDING

Large summary table with columns: YEAR BLT, NET AREA, \$NLA(RCN), CAPACITY, UNITS, ADJ, ELEMENT, CD, DESCRIPTION, ADJ, S, BAT, T, DESCRIPTION, UNITS, YB, ADJ PRICE, RCN, TOTAL RCN, 499,898, CONDITION ELEM, CD, EFF.YR/AGE, 1997 / 25, COND, FUNC, ECON, DEPR, RCNLD, \$389,900.