

Key: 6194

Town of Bourne - Fiscal Year 2024

12/18/2023 6:02 pm SEQ #: 6.352

LEGALS

CURRENT OWNER				PARCEL ID				LOCATION			
NORWOOD RICHARD C JR & CYNTHIA S NORWOOD PO BOX 166 MONUMENT BEACH, MA 02553-0166				30.2-74-0				28 CENTRAL BLVD			
TRANSFER HISTORY				DOS	T	SALE PRICE	BK-PG (Cert)				
NORWOOD RICHARD C JR & NORWOOD RICHARD C JR				09/27/2011	F	100	(195273)				
NORWOOD RICHARD C JR				05/04/2010	F	1	(191314)				
NORWOOD DOROTHY E				12/18/1964	A		(34167)				

CLASS	CLASS%	DESCRIPTION			BN ID	BN	CARD	
1010	100	SINGLE FAMILY				1	1 of 1	
PMT NO	PMT DT	TY	DESC	AMOUNT	INSP	BY	1st	%
19697	07/31/2019	15	INSULATE/WEA	5,000			100	100
11550	09/19/2011	2	ADDITIONS	170,000	08/06/2013	TL	100	100

LAND

CD	T	AC/SF/UN	Nbhd	Infl1	N Index	ADJ BASE	SAF	Topo	Lpi	VC	CREDIT AMT	ADJ VALUE
100	S	31,358 9		1.00	100 1.00	294,625	1.20	A	1.00	PGD 1.25		253,540

TOTAL	31,363 SF	ZONING	1	FRNT	0	ASSESSED	CURRENT	PREVIOUS
Nbhd	MO BCH	NOTE				LAND	253,500	224,400
Infl1	AVG		BUILDING	415,000	371,000			
N_Index	AVG		DETACHED	8,400	8,100			
			OTHER	0	0			
						TOTAL	676,900	603,500

DETAILED

TY	QUAL	COND	DIM/NOTE	YB	UNITS	ADJ PRICE	RCNLD	PHOTO
DGF	A	1.00 A	0.75 12 X 20		240	46.93	8,400	08/06/2013

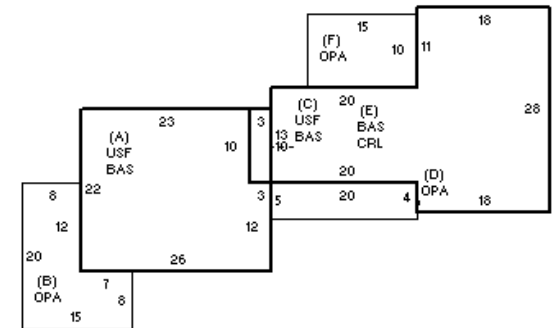

BUILDING

BUILDING	CD	ADJ	DESC	MEASURE	1/15/2014	TL
MODEL	1		RESIDENTIAL	LIST	1/15/2014	TL
STYLE	5	1.00	COLONIAL [100%]	REVIEW	10/20/2020	TL
QUALITY	+	1.05	AVERAGE + [100%]			
FRAME	1	1.00	WOOD FRAME [100%]			

BLDG COMMENTS

G

YEAR BLT	1927	SIZE ADJ	1.010	ELEMENT	CD	DESCRIPTION	ADJ	S	BAT	T	DESCRIPTION	UNITS	YB	ADJ PRICE	RCN	TOTAL RCN	427,834		
NET AREA	1,908	DETAIL ADJ	1.000	FOUNDATION	1	PIER	1.00	A	BAS	L	BASE AREA	542	1927	211.32	114,533	CONDITION ELEM	CD		
\$NLA(RCN)	\$224	OVERALL	1.060	EXT COVER	1	WOOD SHINGLE	1.02	A	USF	L	UPPER STORY FIN	542	1927	123.69	67,041	EXTERIOR	A		
				ROOF SHAPE	3	GAMBREL	1.00	+	OPA	N	OPEN PORCH	466		66.16	30,829	INTERIOR	G		
				ROOF COVER	2	WOOD SHINGLES	1.02	+	BAS	L	BASE AREA	794	2011	211.32	167,785	KITCHEN	G		
				FLOOR COVER	1	HARDWOOD	1.02	C	USF	L	UPPER STORY FIN	30	2011	123.69	3,711	BATHS	G		
				INT. FINISH	2	DRYWALL	1.00	E	CRL	N	BSMT CRAWL	764		28.88	22,062	HEAT	U		
				HEATING/COOLING	1	FORCED AIR	1.00	F21	O	FPL 2S 1OP	1		9,902.50	9,903	ELECT	U			
				FUEL SOURCE	2	GAS	1.00	FIX	O	XTRA FIXTURES	5		2,393.94	11,970					
				USE	0		1.00												
																		EFF.YR/AGE	2016 / 6
																		COND	3 3 %
																		FUNC	0
																		ECON	0
																		DEPR	3 % GD 97
																		RCNLD	\$415,000