

Key: 6358

Town of Bourne - Fiscal Year 2024

12/18/2023 6:02 pm SEQ #: 6.511

LEGALS  
LAND

CURRENT OWNER		PARCEL ID			LOCATION							
NOLAN LEONARD F TRS NOLAN FAMILY IRREV TRUST 11 WOOD LANE WINCHESTER, MA 01890		30.4-28-0			11 MONUMENT AVE							
TRANSFER HISTORY		DOS	T	SALE PRICE	BK-PG (Cert)							
NOLAN LEONARD F TRS NOLAN LEONARD F &		03/28/2022 09/01/1989	F QS	1 200,000	35004-292 6867-69							
CD	T	AC/SF/UN	Nbhd	Infl1	N Index	ADJ BASE	SAF	Topo	Lpi	VC	CREDIT AMT	ADJ VALUE
100	S	8,833 9	1.00	100	1.00	459,615	3.50	A	1.00	BGD	1.95	326,600

LAND

TOTAL	8,843 SF	ZONING	1	FRNT	0	ASSESSED	CURRENT	PREVIOUS		
Nbhd	MO BCH	NOTE across street from tennis courts, playground & beach; great view	LAND		326,600	318,700	BUILDING		460,500	407,600
Infl1	AVG		DETACHED		26,500	25,300	OTHER		0	0
N_Index	AVG		TOTAL		813,600	751,600				

DETACHED

TY	QUAL	COND	DIM/NOTE	YB	UNITS	ADJ PRICE	RCNLD
IPG	E	1.90	10 0.90 14 X 34	2021	476	58.33	25,000
PTD	E	1.90	10 0.90 EST	2021	212	8.04	1,500



CLASS	CLASS%	DESCRIPTION		BN ID	BN	CARD	
1010	100	SINGLE FAMILY			1	1 of 1	
PMT NO	PMT DT	TY	DESC	AMOUNT	INSP	BY	1st %
B-21-111	03/19/2021	8	POOL	40,000	04/26/2022		100 100
		3	ALT/RENO		10/22/2020	TL	100 100
20329	04/27/2020	3	ALT/RENO	22,000	10/22/2020	TL	100 100
H161	04/27/2020	3	ALT/RENO		10/22/2020	TL	100 100
06480	08/04/2006	9	DECK	9,000	09/08/2008	TL	100 100

BUILDING

BUILDING	CD	ADJ	DESC	MEASURE	6/18/2014	TL
MODEL	1		RESIDENTIAL	LIST	1/5/2022	EST
STYLE	7	1.00	CONVENTIONAL [100%]			
QUALITY	A	1.00	AVERAGE [100%]			
FRAME	1	1.00	WOOD FRAME [100%]	REVIEW	1/5/2022	TL

BLDG COMMENTS		

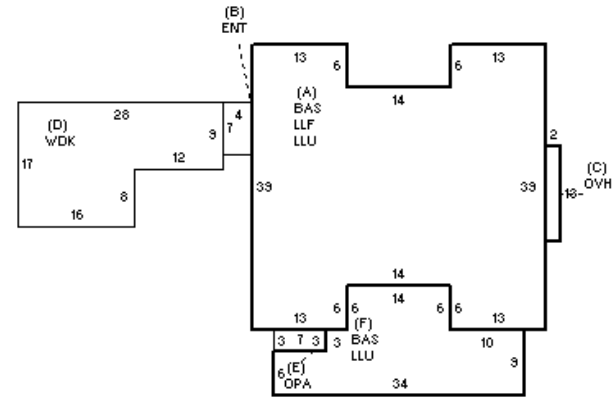

YEAR BLT	1906	SIZE ADJ	0.995
NET AREA	3,179	DETAIL ADJ	1.000
\$NLA(RCN)	\$165	OVERALL	1.090
CAPACITY		UNITS	ADJ
STORIES	1	1.00	
ROOMS	7	1.00	
BEDROOMS	3	1.00	
BATHROOMS	2	1.00	
FIXTURES	10	1.00	
GARAGE CAPACITY	1	1.00	
% BSMT FINISH	50	1.00	
# OF HALF BATHS	0	1.00	
# OF UNITS	1	1.00	

ELEMENT	CD	DESCRIPTION	ADJ
FOUNDATION	4	FLR/WALL(FULL)	1.00
EXT COVER	1	WOOD SHINGLE	1.02
ROOF SHAPE	2	HIP	1.02
ROOF COVER	1	ASPH/COMP SHIN	1.00
FLOOR COVER	1	HARDWOOD	1.02
INT. FINISH	2	DRYWALL	1.00
HEATING/COOLING	9	WARM-COOL AIR	1.03
FUEL SOURCE	1	OIL	1.00
USE	0		1.00

S	BAT	T	DESCRIPTION	UNITS	YB	ADJ PRICE	RCN
+	LLU	N	LOWER LEVEL UNF	1,761		33.21	58,485
A	LLF	L	LOWER LEVEL FIN	1,392	1906	57.41	79,918
+	BAS	L	BASE AREA	1,761	1906	192.09	338,272
B	ENT	N	ENCLOSED ENTRY	28		91.68	2,567
C	OVH	L	OVERHANG	26	1906	196.43	5,107
D	WDK	N	WOOD DECK	380		23.17	8,803
E	OPA	N	OPEN PORCH	21		103.13	2,166
	BMG	O	BSMT GARAGE	1		7,730.70	7,731
	F11	O	FPL 1S TOP	1		8,695.90	8,696
	FIX	O	XTRA FIXTURES	5		2,309.66	11,548

TOTAL RCN	523,294
CONDITION ELEM CD	
EXTERIOR	A
INTERIOR	A
KITCHEN	G
BATHS	G
HEAT	U
ELECT	U
EFF.YR/AGE	2007 / 15
COND	12 12 %
FUNC	0
ECON	0
DEPR	12 % GD 88
RCNLD	\$460,500