

Key: 6384

Town of Bourne - Fiscal Year 2024

12/18/2023 6:02 pm SEQ #: 6.535

LEG  
A  
L  
L  
A  
N  
D

CURRENT OWNER				PARCEL ID				LOCATION				
STELLER MICHAEL A PO BOX 200 MONUMENT BEACH, MA 02553				30.4-58-0				68 MONUMENT AVE				
TRANSFER HISTORY				DOS	T	SALE PRICE	BK-PG (Cert)					
STELLER MICHAEL A				02/21/2019	H	1 (218652)						
STELLER MICHAEL A ETUX				07/31/2009	QS	825,000 (189167)						
O'BRIEN WILLIAM ETUX				05/30/2006	QS	970,000 (180172)						
CD	T	AC/SF/UN	Nbhd	Infl1	N Index	ADJ BASE	SAF	Topo	Lpi	VC	CREDIT AMT	ADJ VALUE
100	S	13,500 9		1.00	100 1.00	1,508,480	2.39	A	1.00	BSP	6.40	1,118,780

CLASS	CLASS%	DESCRIPTION			BN ID	BN	CARD	
1010	100	SINGLE FAMILY				1	1 of 1	
PMT NO	PMT DT	TY	DESC	AMOUNT	INSP	BY	1st	%
14790	09/23/2014	3	ALT/RENO	5,500	05/15/2015	SW	100	100
11082	03/08/2012	2	ADDITIONS	29,500	05/15/2015	SW	100	100
02491	07/26/2002	9	DECK	20,800	09/30/2002	TL	100	100
02147	03/25/2002	9	DECK	4,900	09/30/2002	TL	100	100
02120	03/11/2002	3	ALT/RENO	7,600	08/14/2002	TL	100	100

D  
E  
T  
A  
C  
H  
E  
D

TOTAL	13,504 SF	ZONING	1	FRNT	0	ASSESSED	CURRENT	PREVIOUS
Nbhd	MO BCH	NOTE	LAND	1,118,800	990,200			
Infl1	AVG		BUILDING	269,000	238,000			
N_Index	AVG		DETACHED	0	0			
			OTHER	0	0			
			TOTAL	1,387,800	1,228,200			

TY	QUAL	COND	DIM/NOTE	YB	UNITS	ADJ PRICE	RCNLD

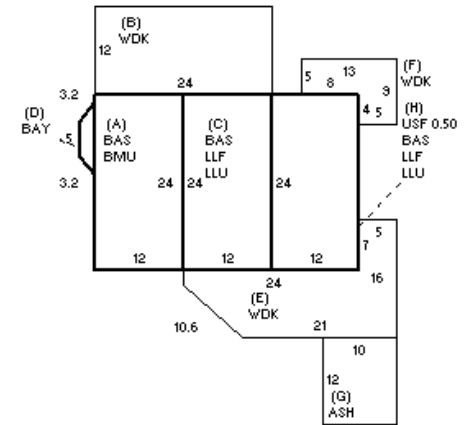

B  
U  
I  
L  
D  
I  
N  
G

BUILDING	CD	ADJ	DESC	MEASURE	5/15/2015	SW
MODEL	1		RESIDENTIAL	LIST	5/15/2015	EST
STYLE	17	1.05	RAISED CAPE [100%]	REVIEW	9/14/2016	DB
QUALITY	A	1.00	AVERAGE [100%]			
FRAME	1	1.00	WOOD FRAME [100%]			

BLDG COMMENTS

YEAR BLT	1970	SIZE ADJ	1.010	ELEMENT	CD	DESCRIPTION	ADJ	S	BAT	T	DESCRIPTION	UNITS	YB	ADJ PRICE	RCN	TOTAL RCN	349,289			
NET AREA	1,791	DETAIL ADJ	1.000	FOUNDATION	4	FLR/WALL(FULL)	1.00	A	BMU	N	BSMT UNFINISHED	288		68.20	19,641	CONDITION ELEM	CD			
\$NLA(RCN)	\$195	OVERALL	1.100	EXT COVER	2	CLAPBOARD	1.00	+	BAS	L	BASE AREA	864	1970	220.32	190,353	EXTERIOR	A			
				ROOF SHAPE	1	GABLE	1.00	+	WDK	N	WOOD DECK	641		23.73	15,212	INTERIOR	A			
				ROOF COVER	1	ASPH/COMP SHIN	1.00	+	LLU	N	LOWER LEVEL UNF	576		40.28	23,202	KITCHEN	A			
				FLOOR COVER	1	HARDWOOD	1.02	+	LLF	L	LOWER LEVEL FIN	576	1970	68.55	39,487	BATHS	A			
				INT. FINISH	2	DRYWALL	1.00	D	BAY	L	BAYWINDOW	15	1970	201.24	3,019	HEAT	A			
				HEATING/COOLING	9	WARM-COOL AIR	1.03	G	ASH	N	ATT SHED	120		25.76	3,091	ELECT	A			
				FUEL SOURCE	2	GAS	1.00	H	USF	L	UPPER STORY FIN	144	2011	122.25	17,604					
				USE	0		1.00	USF	L	UPPER STORY FIN	192	1970	122.24	23,471						
												FIX	O	XTRA FIXTURES	3		2,366.07	7,098		
												GFP	O	GAS FIREPLACE	1		7,110.40	7,110		
																EFF.YR/AGE	1996 / 26			
																COND	23 23 %			
																FUNC	0			
																ECON	0			
																DEPR	23	% GD	77	
																RCNLD	\$269,000			