

Key: 6455

Town of Bourne - Fiscal Year 2024

12/18/2023 6:02 pm SEQ #: 6.610

LEGAL

LAND

CURRENT OWNER		PARCEL ID		LOCATION	
RICKER RACHEL L & DANIEL B TRS RICKER REVOCABLE TRUST 2014 12 MERRILL RD MERRIMACK, NH 03054		30.4-133-0		51 BEACH ST	
TRANSFER HISTORY		DOS	T	SALE PRICE	BK-PG (Cert)
RICKER RACHEL L & DANIEL THORNTON SCOTT		10/29/2020	QS	490,000	33413-209
PILKINGTON HAROLD & EVEL		08/28/2017	H XX	304,475	30726-311 1051+-173+

CLASS	CLASS%	DESCRIPTION		BN ID	BN	CARD	
1010	100	SINGLE FAMILY			1	1 of 1	
PMT NO	PMT DT	TY	DESC	AMOUNT	INSP	BY	1st %
0000		3	ALT/RENO		12/30/2020	TL	100 100
18870-B	10/17/2018	9	DECK	5,150	11/12/2019	TL	100 100
18870	10/10/2018	9	DECK	5,150	11/12/2019	TL	100 100
18037	01/18/2018	15	INSULATE/WEA	5,000			100 100
18014	01/05/2018	15	INSULATE/WEA	4,816			100 100

CD	T	AC/SF/UN	Nbhd	Infl1	N Index	ADJ BASE	SAF	Topo	Lpi	VC	CREDIT AMT	ADJ VALUE			
100	S	40,000	9	1.00	100	1.00	100	1.00	271,055	1.00	A	1.00	BAV	1.15	248,850
300	A	0.144	9	1.00	100	1.00	100	1.00	18,745	1.00	A	1.00	BAV	1.15	2,700

TOTAL	1.062 Acres	ZONING	1	FRNT	0	ASSESSED	CURRENT	PREVIOUS
Nbhd	MO BCH	NOTE	LAND	251,600	222,600			
Infl1	AVG		BUILDING	412,600	365,100			
N_Index	AVG		DETACHED	0	0			
			OTHER	0	0			
			TOTAL	664,200	587,700			

DETACHED

TY	QUAL	COND	DIM/NOTE	YB	UNITS	ADJ PRICE	RCNLD



BLDG COMMENTS

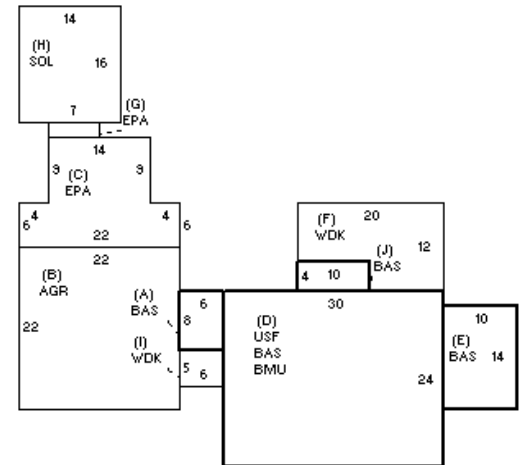

BU I L D I N G

BUILDING	CD	ADJ	DESC	MEASURE	11/12/2019	TL
MODEL	1		RESIDENTIAL	LIST	11/12/2019	TL
STYLE	5	1.00	COLONIAL [100%]	REVIEW	2/5/2021	RP
QUALITY	+	1.05	AVERAGE + [100%]			
FRAME	1	1.00	WOOD FRAME [100%]			

YEAR BLT	1945	SIZE ADJ	1.010	ELEMENT	CD	DESCRIPTION	ADJ	S	BAT	T	DESCRIPTION	UNITS	YB	ADJ PRICE	RCN	TOTAL RCN	485.373
NET AREA	1,668	DETAIL ADJ	1.000	FOUNDATION	4	FLR/WALL(FULL)	1.00	+	BAS	L	BASE AREA	908	1945	229.23	208,140	CONDITION ELEM	CD
\$NLA(RCN)	\$291	OVERALL	1.090	EXT COVER	1	WOOD SHINGLE	1.02	B	AGR	N	ATT GARAGE	484		71.44	34,579	EXTERIOR	G
				ROOF SHAPE	3	GAMBREL	1.00	+	EPA	N	ENCLOSED PORCH	272		75.41	20,511	INTERIOR	G
				ROOF COVER	1	ASPH/COMP SHIN	1.00	D	BMU	N	BSMT UNFINISHED	720		53.21	38,310	KITCHEN	G
				FLOOR COVER	2	SOFTWOOD	1.02	D	USF	L	UPPER STORY FIN	720	1945	125.69	90,497	BATHS	G
				INT. FINISH	1	PLASTER	1.00	+	WDK	N	WOOD DECK	270		29.94	8,084	HEAT	A
				HEATING/COOLING	11	HT WATER CL AIR	1.05	H	SOL	N	SOLARIUM	224		99.69	22,331	ELECT	A
				FUEL SOURCE	1	OIL	1.00	J	BAS	L	BASE AREA	40	2019	229.23	9,169		
				USE	0		1.00	BGF	N	BSMT GOOD FINIS	360		86.84	31,263			
								F21	O	FPL 2S IOP	1		10,182.70	10,183			
								FIX	O	XTRA FIXTURES	5		2,461.70	12,309			

CAPACITY	UNITS	ADJ	EFF.YR/AGE	2004 / 18
STORIES	2	1.00	COND	15 15 %
ROOMS	6	1.00	FUNC	0
BEDROOMS	2	1.00	ECON	0
BATHROOMS	2	1.00	DEPR	15 % GD 85
FIXTURES	10	1.00	RCNLD	\$412,600
GARAGE CAPACITY	2	1.00		
% BSMT FINISH	0	1.00		
# OF HALF BATHS	1	1.00		
# OF UNITS	1	1.00		