

Key: 6465

Town of Bourne - Fiscal Year 2024

12/18/2023 6:02 pm SEQ #: 6.624

LEGAL

LAND

DETACHED

BUILDING

CURRENT OWNER				PARCEL ID				LOCATION			
EDWARDS BEATRIX M TR BME AND JROC REALTY TRUST 67 CLIFF RD BOURNE, MA 02532				30.4-142-0				67 CLIFF RD			
TRANSFER HISTORY				DOS	T	SALE PRICE	BK-PG (Cert)				
EDWARDS BEATRIX M TR				10/23/2013	QS	285,000	27775-286				
SCHMIDT DOUGLAS S				03/31/2006	N	298,600	20874-257				
BERNIER RONALD P ETAL				03/31/2006	F		20874-255				

CLASS	CLASS%	DESCRIPTION			BN ID	BN	CARD	
1010	100	SINGLE FAMILY				1	1 of 1	
PMT NO	PMT DT	TY	DESC	AMOUNT	INSP	BY	1st	%
EXB-21-544	08/05/2021	3	ALT/RENO	2,600			100	100
EXB-21-160	03/10/2021	3	ALT/RENO	17,550			100	100
15893	10/08/2015	14	SOLAR	27,300			100	100
200520	08/22/2000	3	ALT/RENO	1,844	09/11/2001	TL	100	100

CD	T	AC/SF/UN	Nbhd	Infl1	N Index	ADJ BASE	SAF	Topo	Lpi	VC	CREDIT AMT	ADJ VALUE			
100	S	40,000	9	1.00	100	1.00	100	1.00	235,700	1.00	A	1.00	R04	1.00	216,390
300	A	0.352	9	1.00	100	1.00	100	1.00	16,300	1.00	A	1.00	R04	1.00	5,740

TOTAL	1.270 Acres		ZONING	1	FRNT	0	ASSESSED	CURRENT	PREVIOUS
Nbhd	MO BCH		NOTE			LAND	222,100	196,600	
Infl1	AVG			BUILDING	276,900	248,400			
N_Index	AVG			DETACHED	0	0			
				OTHER	0	0			
						TOTAL	499,000	445,000	

TY	QUAL	COND	DIM/NOTE	YB	UNITS	ADJ PRICE	RCNLD
SHF	A	1.00	A 0.75 8 X 8			0.00	



BUILDING	CD	ADJ	DESC	MEASURE	10/28/2020	TL
MODEL	1		RESIDENTIAL	LIST	10/28/2020	EST
STYLE	1	0.95	RANCH [100%]	REVIEW	7/13/2022	RP
QUALITY	A	1.00	AVERAGE [100%]			
FRAME	1	1.00	WOOD FRAME [100%]			

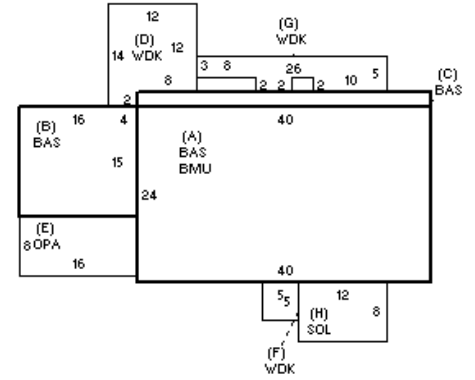

YEAR BLT	1981	SIZE ADJ	1.015	ELEMENT	CD	DESCRIPTION	ADJ	S	BAT	T	DESCRIPTION	UNITS	YB	ADJ PRICE	RCN	TOTAL RCN	374,223
NET AREA	1,280	DETAIL ADJ	1.000	FOUNDATION	4	FLR/WALL(FULL)	1.00	A	BMU	N	BSMT UNFINISHED	960		37.38	35,886		
\$NLA(RCN)	\$292	OVERALL	1.010	EXT COVER	1	WOOD SHINGLE	1.02	B	BAS	L	BASE AREA	240	2021	192.71	46,251		
				ROOF SHAPE	1	GABLE	1.00	+	BAS	L	BASE AREA	1,040	1981	192.71	200,418		
				ROOF COVER	1	ASPH/COMP SHIN	1.00	+	WDK	N	WOOD DECK	285		26.55	7,567		
				FLOOR COVER	1	HARDWOOD	1.02	E	OPA	N	OPEN PORCH	128		70.34	9,003		
				INT. FINISH	2	DRYWALL	1.00	H	SOL	N	SOLARIUM	96		112.32	10,783		
				HEATING/COOLING	2	HOT WATER	1.02		BMF	N	BSMT FINISH	600		44.92	26,950		
				FUEL SOURCE	2	GAS	1.00		FIX	O	XTRA FIXTURES	10		2,183.16	21,832		
				USE	0		1.00		KIT	O	EXTRA KITCHEN	1		5,149.30	5,149		
									MST	O	MAS/METAL STACK	1		4,091.40	4,091		
									WPL	O	WHIRLPOOL	1		6,293.40	6,293		

CONDITION ELEM	CD
EXTERIOR	G
INTERIOR	A
KITCHEN	A
BATHS	A
HEAT	A
ELECT	A

EFF. YR/AGE	2002 / 20	
COND	17	17 %
FUNC	9	
ECON	0	
DEPR	26	% GD 74

RCNLD	\$276,900
-------	-----------