

Key: 6714

Town of Bourne - Fiscal Year 2024

12/18/2023 6:02 pm SEQ #: 6.882

LEGALS

CURRENT OWNER				PARCEL ID				LOCATION			
ROBINSON BERNADETTE & DANIEL TRS BERNADETTE ROBINSON 2021 PO BOX 34 MONUMENT BEACH, MA 02553				31.0-68-0				28 SHAKER DR			
TRANSFER HISTORY				DOS	T	SALE PRICE	BK-PG (Cert)				
ROBINSON BERNADETTE & DAN				12/08/2021	F	1	34729-75				
ROBINSON DANIEL E ETUX				04/29/2003	F		16827-185				
ROBINSON DANIEL E &				12/22/1999	QS	240,904	12738-151				

CLASS	CLASS%	DESCRIPTION			BN ID	BN	CARD	
1010	100	SINGLE FAMILY				1	1 of 1	
PMT NO	PMT DT	TY	DESC	AMOUNT	INSP	BY	1st	%
200805	12/26/2000	3	ALT/RENO	18,000	09/11/2001	TL	100	100
200111	03/13/2000	4	DETACH.STRUC	1,200	07/20/2000	TL	100	100
990428	07/19/1999	1	NEW CONSTRUC	140,000	11/04/1999	MS	100	100

LAND

CD	T	AC/SF/UN	Nbhd	Infl1	N Index	ADJ BASE	SAF	Topo	Lpi	VC	CREDIT AMT	ADJ VALUE						
100	S	17,466	9	1.00	100	1.00	1.00	1.00	259,270	1.92	A	1.00	R06	1.10				199,130

TOTAL	17,468 SF	ZONING	1	FRNT	0	ASSESSED	CURRENT	PREVIOUS
Nbhd	MO BCH	NOTE	LAND	199,100	176,200			
Infl1	AVG		BUILDING	423,500	379,200			
N_Index	AVG		DETACHED	0	0			
			OTHER	0	0			
			TOTAL	622,600	555,400			

DETACHED

TY	QUAL	COND	DIM/NOTE	YB	UNITS	ADJ PRICE	RCNLD
SHF	A	1.00	A 0.75 8 X 12			0.00	

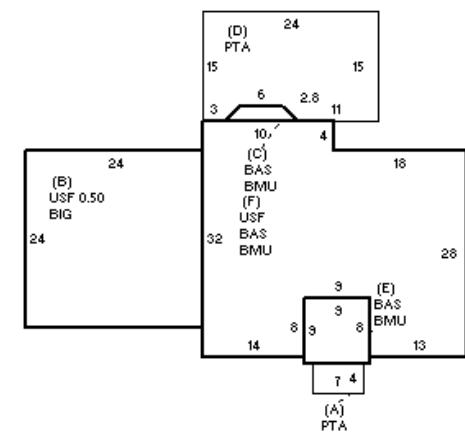

BUILDING

BUILDING	CD	ADJ	DESC	MEASURE	8/16/2017	TL
MODEL	1		RESIDENTIAL	LIST	8/16/2017	TL
STYLE	5	1.00	COLONIAL [100%]	REVIEW		
QUALITY	+	1.05	AVERAGE + [100%]			
FRAME	1	1.00	WOOD FRAME [100%]			

BLDG COMMENTS

G

YEAR BLT	1999	SIZE ADJ	1.005	ELEMENT	CD	DESCRIPTION	ADJ	S	BAT	T	DESCRIPTION	UNITS	YB	ADJ PRICE	RCN	TOTAL RCN	504,148	
NET AREA	2,401	DETAIL ADJ	1.000	FOUNDATION	4	FLR/WALL(FULL)	1.00	+	PTA	N	PATIO	372		14.92	5,551			
\$NLA(RCN)	\$210	OVERALL	1.040	EXT COVER	1	WOOD SHINGLE	1.02	B	BIG	N	BUILT-IN GARAGE	576		86.05	49,562			
				ROOF SHAPE	1	GABLE	1.00	+	USF	L	UPPER STORY FIN	1,296	1999	114.10	147,875			
				ROOF COVER	1	ASPH/COMP SHIN	1.00	+	BMU	N	BSMT UNFINISHED	1,105		40.02	44,221			
				FLOOR COVER	1	HARDWOOD	1.02	+	BAS	L	BASE AREA	1,105	1999	210.67	232,795			
				INT. FINISH	2	DRYWALL	1.00	F22	O	FPL 2S 2OP	1			10,119.70	10,120			
				HEATING/COOLING	1	FORCED AIR	1.00	FIX	O	XTRA FIXTURES	6			2,337.22	14,023			
				FUEL SOURCE	2	GAS	1.00											
				USE	0		1.00											
																EFF.YR/AGE	2003 / 19	
																COND	16 16 %	
																FUNC	0	
																ECON	0	
																DEPR	16 % GD 84	
																RCNLD	\$423,500	