

Key: 6921

Town of Bourne - Fiscal Year 2024

12/18/2023 6:02 pm SEQ #: 7.085

LEGAL

LAND

DETACHED

BUILDING

CURRENT OWNER				PARCEL ID				LOCATION			
CURTIS ROBERT 101 CLAY POND RD BOURNE, MA 02532				31.3-183-0				101 CLAY POND RD			
TRANSFER HISTORY				DOS	T	SALE PRICE	BK-PG (Cert)				
CURTIS ROBERT				11/05/2010	F	1	24974-181				
CURTIS ROBERT				06/11/2010	F	1	24610-14				
CURTIS ELMIRE M				02/24/2009	F	1	23474-41				

CLASS	CLASS%	DESCRIPTION			BN ID	BN	CARD	
1010	100	SINGLE FAMILY				1	1 of 1	
PMT NO	PMT DT	TY	DESC	AMOUNT	INSP	BY	1st	%
EXB-21-193	03/18/2021	15	INSULATE/WEA	1,533			100	100
18304	04/18/2018	14	SOLAR	7,139			100	100
15612	07/21/2015	14	SOLAR	24,700			100	100
09234	06/04/2009	3	ALT/RENO	22,000	11/24/2009	TL	100	100
05145	03/07/2005	3	ALT/RENO	10,900	06/03/2005	TL	100	100

CD	T	AC/SF/UN	Nbhd	Infl1	N Index	ADJ BASE	SAF	Topo	Lpi	VC	CREDIT AMT	ADJ VALUE
100	S	24,637 9	1.00	100	1.00	235,700	1.44	A	1.00	R04	1.00	192,280

TOTAL	24,655 SF	ZONING	1	FRNT	0	ASSESSED	CURRENT	PREVIOUS
Nbhd	MO BCH	NOTE	LAND	192,300	170,200			
Infl1	AVG		BUILDING	245,500	217,300			
N_Index	AVG		DETACHED	0	0			
			OTHER	0	0			
		TOTAL	437,800	387,500				

TY	QUAL	COND	DIM/NOTE	YB	UNITS	ADJ PRICE	RCNLD	PHOTO
								12/02/2009

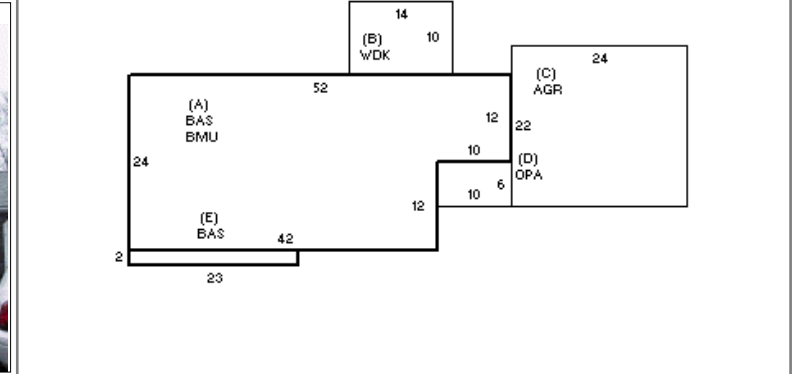

BUILDING	CD	ADJ	DESC	MEASURE	12/15/2009	TL
MODEL	1		RESIDENTIAL	LIST	12/15/2009	TL
STYLE	1	0.95	RANCH [100%]	REVIEW	3/17/2017	DB
QUALITY	A	1.00	AVERAGE [100%]			
FRAME	1	1.00	WOOD FRAME [100%]			

BLDG COMMENTS		

YEAR BLT	1974	SIZE ADJ	1.015	ELEMENT	CD	DESCRIPTION	ADJ	S	BAT	T	DESCRIPTION	UNITS	YB	ADJ PRICE	RCN	TOTAL RCN	318,820	
NET AREA	1,174	DETAIL ADJ	1.000	FOUNDATION	4	FLR/WALL(FULL)	1.00	A	BMU	N	BSMT UNFINISHED	1,128		36.64	41,332	CONDITION ELEM	CD	
\$NLA(RCN)	\$272	OVERALL	0.990	EXT COVER	1	WOOD SHINGLE	1.02	B	WDK	N	WOOD DECK	140		39.71	5,559	EXTERIOR	A	
CAPACITY			UNITS	ADJ	ROOF SHAPE	1	GABLE	1.00	C	AGR	N	ATT GARAGE	528		62.10	32,791	INTERIOR	A
STORIES	1	1.00	1	1.00	ROOF COVER	1	ASPH/COMP SHIN	1.00	D	OPA	N	OPEN PORCH	60		77.01	4,620	KITCHEN	A
ROOMS	5	1.00	1	1.00	FLOOR COVER	3	W/W CARPET	1.00	+	BAS	L	BASE AREA	1,174	1974	192.90	226,461	BATHS	A
BEDROOMS	3	1.00	1	1.00	INT. FINISH	2	DRYWALL	1.00	F11	O	FPL 1S 1OP	1		8,056.90	8,057	HEAT	A	
BATHROOMS	1	1.00	1	1.00	HEATING/COOLING	2	HOT WATER	1.02									ELECT	A
FIXTURES	5	1.00	1	1.00	FUEL SOURCE	1	OIL	1.00										
GARAGE CAPACITY	2	1.00	1	1.00	USE	0		1.00										
% BSMT FINISH	0	1.00																
# OF HALF BATHS	0	1.00																
# OF UNITS	1	1.00																
																EFF.YR/AGE	1996 / 26	
																COND	23 23 %	
																FUNC	0	
																ECON	0	
																DEPR	23 % GD 77	
																RCNLD	\$245,500	