

Key: 6986

Town of Bourne - Fiscal Year 2024

12/18/2023 6:02 pm SEQ #: 7.130

LEGAL

CURRENT OWNER				PARCEL ID				LOCATION			
CARON GARY J 22 LAURA LANE BOURNE, MA 02532				31.4-31-0				22 LAURA LN			
TRANSFER HISTORY				DOS	T	SALE PRICE		BK-PG (Cert)			
CARON GARY J				07/31/2015	QS	255,000		29050-176			
CLARK MICHAEL T &				06/28/2004	QS	290,000		18768-320			
PACHECO SUSAN				09/03/2003	QS	243,000		17581-253			

CLASS	CLASS%	DESCRIPTION			BN ID	BN	CARD	
1010	100	SINGLE FAMILY				1	1 of 1	
PMT NO	PMT DT	TY	DESC	AMOUNT	INSP	BY	1st	%
000	06/01/2015	13	OTHER		06/01/2015	DB	100	100
920548	10/26/1992	10	WOODSTOVE	1,200	04/06/1993	JS	100	100

LAND

CD	T	AC/SF/UN	Nbhd	Infl1	N Index	ADJ BASE	SAF	Topo	Lpi	VC	CREDIT AMT	ADJ VALUE
100	S	17,073 9		1.00	100 1.00	235,700	1.95	A	1.00	R04	1.00	180,410

TOTAL	17,076 SF	ZONING	1	FRNT	0	ASSESSED	CURRENT	PREVIOUS
Nbhd	MO BCH	NOTE				LAND	180,400	159,700
Infl1	AVG		BUILDING	265,800	235,200			
N_Index	AVG		DETACHED	2,100	2,000			
			OTHER	0	0			
						TOTAL	448,300	396,900

DETACHED

TY	QUAL	COND	DIM/NOTE	YB	UNITS	ADJ PRICE	RCNLD
SHF	G	1.20 10 0.90	10X12		120	19.71	2,100

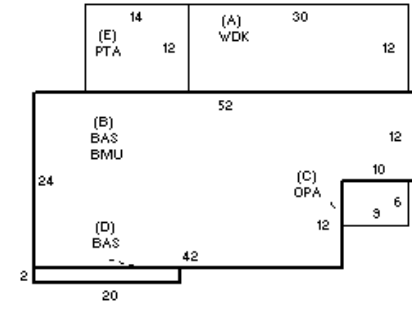

BUILDING

BUILDING	CD	ADJ	DESC	MEASURE	6/1/2015	DB
MODEL	1		RESIDENTIAL	LIST	6/1/2015	EST
STYLE	1	0.95	RANCH [100%]	REVIEW	6/1/2015	TL
QUALITY	A	1.00	AVERAGE [100%]			
FRAME	1	1.00	WOOD FRAME [100%]			

BLDG COMMENTS

G

YEAR BLT	1983	SIZE ADJ	1.015	ELEMENT	CD	DESCRIPTION	ADJ	S	BAT	T	DESCRIPTION	UNITS	YB	ADJ PRICE	RCN	TOTAL RCN	316,371	
NET AREA	1,168	DETAIL ADJ	1.000	FOUNDATION	4	FLR/WALL(FULL)	1.00	A	WDK	N	WOOD DECK	360		21.03	7,571			
\$NLA(RCN)	\$271	OVERALL	0.970	EXT COVER	1	WOOD SHINGLE	1.02	B	BMU	N	BSMT UNFINISHED	1,128		35.90	40,497			
				ROOF SHAPE	1	GABLE	1.00	C	OPA	N	OPEN PORCH	54		75.45	4,074			
				ROOF COVER	1	ASPH/COMP SHIN	1.00	+	BAS	L	BASE AREA	1,168	1983	189.00	220,752			
				FLOOR COVER	2	SOFTWOOD	1.02	E	PTA	N	PATIO	168		13.90	2,334			
				INT. FINISH	2	DRYWALL	1.00		BMF	N	BSMT FINISH	900		34.17	30,755			
				HEATING/COOLING	5	ELECTRIC BB	0.98		F12	O	FPL 1S 2OP	1		8,289.90	8,290			
				FUEL SOURCE	3	ELECTRIC	1.00		FIX	O	XTRA FIXTURES	1		2,097.10	2,097			
				USE	0		1.00											
																EFF.YR/AGE	2003 / 19	
																COND	16 16 %	
																FUNC	0	
																ECON	0	
																DEPR	16 % GD 84	
																RCNLD	\$265,800	