

Key: 7026

Town of Bourne - Fiscal Year 2024

12/18/2023 6:02 pm SEQ #: 7.170

LEGALS

CURRENT OWNER				PARCEL ID				LOCATION			
SCARPATO DAVID J ETUX SCARPATO NATASHA A 12 WESTERLY DR BOURNE, MA 02532				31.4-71-0				12 WESTERLY DR			
TRANSFER HISTORY				DOS	T	SALE PRICE	BK-PG (Cert)				
SCARPATO DAVID J ETUX				08/25/2017	QS	400,000	30722-251				
WELLER ROBERT A &				03/10/1980	QS	77,000	3066-325				

CLASS	CLASS%	DESCRIPTION			BN ID	BN	CARD	
1010	100	SINGLE FAMILY				1	1 of 1	
PMT NO	PMT DT	TY	DESC	AMOUNT	INSP	BY	1st	%
19119	02/21/2019	15	INSULATE/WEA	3,773				100
181094	12/19/2018	10	WOODSTOVE		01/31/2018	TL		100
		12	CYCLICAL		08/18/2015			100
10543	09/15/2010	14	SOLAR					100
04503	07/06/2004	3	ALT/RENO	35,000	12/06/2004	TL		100

LAND

CD	T	AC/SF/UN	Nbhd	Infl1	N Index	ADJ BASE	SAF	Topo	Lpi	VC	CREDIT AMT	ADJ VALUE											
100	S	38,224	9	1.00	100	1.00	100	1.00	235,700	1.03	A	1.00	R04	1.00									213,610

TOTAL	38,246 SF	ZONING	1	FRNT	0	ASSESSED	CURRENT	PREVIOUS
Nbhd	MO BCH	NOTE	LAND	213,600	189,100			
Infl1	AVG		BUILDING	324,800	287,400			
N_Index	AVG		DETACHED	2,300	2,200			
			OTHER	0	0			
TOTAL				540,700	478,700			

DETACHED

TY	QUAL	COND	DIM/NOTE	YB	UNITS	ADJ PRICE	RCNLD
SHF	A	1.00	A 0.75 8 X 12			0.00	
WDK	A	1.00	A 0.75 12 X 14		168	18.30	2,300

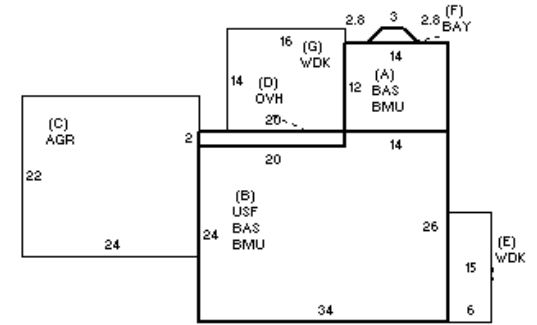

BUILDING

BUILDING	CD	ADJ	DESC	MEASURE	1/31/2018	TL
MODEL	1		RESIDENTIAL	LIST	1/31/2018	TL
STYLE	5	1.00	COLONIAL [100%]	REVIEW	10/17/2019	TL
QUALITY	A	1.00	AVERAGE [100%]			
FRAME	1	1.00	WOOD FRAME [100%]			

BLDG COMMENTS

LOADING

YEAR BLT	1980	SIZE ADJ	1.010	ELEMENT	CD	DESCRIPTION	ADJ	S	BAT	T	DESCRIPTION	UNITS	YB	ADJ PRICE	RCN	TOTAL RCN	411,126
NET AREA	1,906	DETAIL ADJ	1.000	FOUNDATION	4	FLR/WALL(FULL)	1.00	+	BMU	N	BSMT UNFINISHED	1,012		37.57	38,016	CONDITION ELEM	CD
\$NLA(RCN)	\$216	OVERALL	1.020	EXT COVER	1	WOOD SHINGLE	1.02	+	BAS	L	BASE AREA	1,012	1980	197.76	200,137	EXTERIOR	G
				ROOF SHAPE	1	GABLE	1.00	B	USF	L	UPPER STORY FIN	844	1980	110.90	93,601	INTERIOR	A
				ROOF COVER	1	ASPH/COMP SHIN	1.00	C	AGR	N	ATT GARAGE	528		63.67	33,619	KITCHEN	A
				FLOOR COVER	2	SOFTWOOD	1.02	D	OVH	L	OVERHANG	40	1980	186.57	7,463	BATHS	A
				INT. FINISH	2	DRYWALL	1.00	+	WDK	N	WOOD DECK	314		22.01	6,910	HEAT	A
				HEATING/COOLING	5	ELECTRIC BB	0.98	F	BAY	L	BAYWINDOW	10	1980	186.57	1,866	ELECT	A
				FUEL SOURCE	3	ELECTRIC	1.00		BSF	N	BSMT SEMI-FIN	500		18.94	9,471		
				USE	0		1.00		F21	O	FPL 2S 1OP	1		9,075.00	9,075		
									FIX	O	XTRA FIXTURES	5		2,193.92	10,970		
																EFF.YR/AGE	1998 / 24
																COND	21 21 %
																FUNC	0
																ECON	0
																DEPR	21 % GD 79
																RCNLD	\$324,800