

Key: 7295

Town of Bourne - Fiscal Year 2024

12/18/2023 6:02 pm SEQ #: 7.449

LEGAL

CURRENT OWNER				PARCEL ID				LOCATION			
BRALEY KENNETH E & DEBORAH L BRALEY P O BOX 747 MONUMENT BEACH, MA 02553-0747				34.2-77-0				495 SHORE RD			
TRANSFER HISTORY				DOS	T	SALE PRICE	BK-PG (Cert)				
BRALEY KENNETH E &				01/16/1996	D	100,000	(139543)				

CLASS	CLASS%	DESCRIPTION			BN ID	BN	CARD	
1010	100	SINGLE FAMILY				1	1 of 1	
PMT NO	PMT DT	TY	DESC	AMOUNT	INSP	BY	1st	%
08673	12/16/2008	10	WOODSTOVE	550	06/17/2009		100	100
06657	10/13/2006	1	NEW CONSTRUC	330,000	04/25/2023	TL	100	100

LAND

CD	T	AC/SF/UN	Nbhd	Infl1	N Index	ADJ BASE	SAF	Topo	Lpi	VC	CREDIT AMT	ADJ VALUE	
100	S	33,780	9	1.00	100	1.00	271,055	1.13	A	1.00	BAV	1.15	237,630

TOTAL	33,759 SF	ZONING	1	FRNT	0	ASSESSED	CURRENT	PREVIOUS
Nbhd	MO BCH	NOTE	LAND	237,600	210,300			
Infl1	AVG		BUILDING	696,400	417,700			
N_Index	AVG		DETACHED	0	0			
			OTHER	0	0			
			TOTAL	934,000	628,000			

DETACHED

TY	QUAL	COND	DIM/NOTE	YB	UNITS	ADJ PRICE	RCNLD	PHOTO
								04/25/2023
								

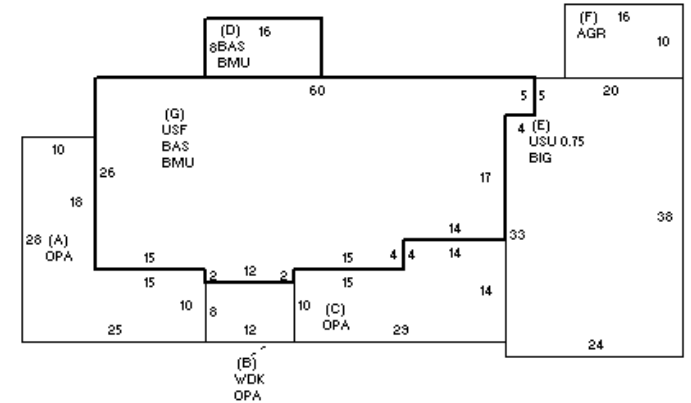

BUILDING	CD	ADJ	DESC	MEASURE	1/25/2019	TL
MODEL	1		RESIDENTIAL	LIST	4/25/2023	TL
STYLE	8	1.10	CONTEMPORARY [100%]	REVIEW	4/25/2023	TL
QUALITY	+	1.05	AVERAGE + [100%]			
FRAME	1	1.00	WOOD FRAME [100%]			

YEAR BLT	2006	SIZE ADJ	0.995	ELEMENT	CD	DESCRIPTION	ADJ	S	BAT	T	DESCRIPTION	UNITS	YB	ADJ PRICE	RCN	TOTAL RCN	791,387
NET AREA	3,016	DETAIL ADJ	1.000	FOUNDATION	4	FLR/WALL(FULL)	1.00	+	OPA	N	OPEN PORCH	872		70.09	61,122		
\$NLA(RCN)	\$262	OVERALL	1.140	EXT COVER	1	WOOD SHINGLE	1.02	B	WDK	N	WOOD DECK	96		52.40	5,031		
CAPACITY								+	BMU	N	BSMT UNFINISHED	1,572		38.05	59,813		
STORIES	2	1.00		ROOF SHAPE	1	GABLE	1.00	+	BAS	L	BASE AREA	1,572	2006	218.50	343,477		
ROOMS	7	1.00		ROOF COVER	1	ASPH/COMP SHIN	1.00	E	BIG	N	BUILT-IN GARAGE	892		83.36	74,360		
BEDROOMS	3	1.00		FLOOR COVER	1	HARDWOOD	1.02	E	USU	N	UPPER STORY UNF	669		55.12	36,879		
BATHROOMS	1	1.00		INT. FINISH	2	DRYWALL	1.00	F	AGR	N	ATT GARAGE	160		102.09	16,335		
FIXTURES	7	1.00		HEATING/COOLING	1	FORCED AIR	1.00	G	USF	L	UPPER STORY FIN	1,444	2006	123.83	178,807		
GARAGE CAPACITY	3	1.00		FUEL SOURCE	2	GAS	1.00		F21	O	FPL 2S 1OP	1		10,491.70	10,492		
% BSMT FINISH	0	1.00		USE	0		1.00		FIX	O	XTRA FIXTURES	2		2,536.25	5,073		
# OF HALF BATHS	1	1.00															
# OF UNITS	0	1.00															

CONDITION ELEM	CD	TOTAL RCN
EXTERIOR	A	
INTERIOR	A	
KITCHEN	A	
BATHS	A	
HEAT	A	
ELECT	A	

EFF.YR/AGE	2007 / 15
COND	12 12 %
FUNC	0 uc
ECON	0
DEPR	12 % GD 88
RCNLD	\$696,400

BUILDING