

Key: 7358

Town of Bourne - Fiscal Year 2024

12/18/2023 6:02 pm SEQ #: 7.505

LEGALS

CURRENT OWNER				PARCEL ID				LOCATION				
HAC LLC 920 MAIN STREET, SUITE 115 KANSAS CITY, MO 64105				35.0-51-0				100 HARMONY HILL				
TRANSFER HISTORY				DOS	T	SALE PRICE	BK-PG (Cert)					
HAC LLC				07/13/2007	P	2,300,000	22185-324					
QAS CORP				05/11/2004	N	1,300,000	18577-21					
COMMUNICA INC				08/01/2000	G	1,400,000	13160-303					
CD	T	AC/SF/UN	Nbhd	Infl1	N Index	ADJ BASE	SAF	Topo	Lpi	VC	CREDIT AMT	ADJ VALUE
112	U	73 APT	100	1.00	100	29,440	1.00	A	1.00	APF	0.80	2,149,120

CLASS	CLASS%	DESCRIPTION			BN ID	BN	CARD	
1140	100	AFFORDABLE HSG UNITS				1	1 of 13	
PMT NO	PMT DT	TY	DESC	AMOUNT	INSP	BY	1st	%
19414	05/14/2019	3	ALT/RENO	10,000			100	100
181049	12/04/2018	4	DETACH.STRUC	9,000	05/13/2019	RP	100	100
17580	07/27/2017	13	OTHER		05/13/2019	RP	100	100
17558	07/17/2017	4	DETACH.STRUC		05/13/2019	RP	100	100
17407 - 16	06/01/2017	1	NEW CONSTRUC	4,000,000	05/13/2019	RP	42	100

LAND

TOTAL	17.161 Acres	ZONING	FRNT	0	ASSESSED	CURRENT	PREVIOUS
Nbhd	APTS	NOTE	LAND	2,149,100	2,044,000		
Infl1	AVG		BUILDING	909,900	885,100		
N_Index	AVG		DETACHED	38,300	36,100		
			OTHER	2,802,100	2,724,300		
TOTAL			TOTAL	5,899,400	5,689,500		

DETACHED

TY	QUAL	COND	DIM/NOTE	YB	UNITS	ADJ PRICE	RCNLD
PAV	A	1.00	10 0.90	2000	12,000	1.20	13,000
LH1	A	1.00	10 0.90	2000	20	845.50	15,200
DGF	A	1.00	10 0.90 12X20	2017	240	46.93	10,100

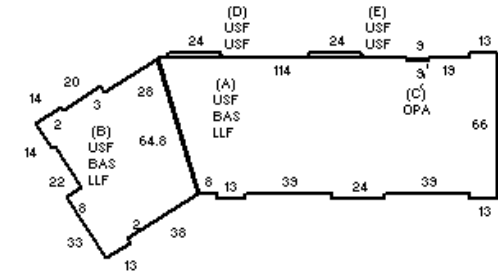

BUILDING

BUILDING	CD	ADJ	DESC	MEASURE	5/13/2019	RP
MODEL	5		CIM-5	LIST	4/8/2019	RP
STYLE	14	0.56	APARTMENTS HH [100%]	REVIEW	5/21/2019	BC
QUALITY	G	1.10	GOOD [100%]			
FRAME	1	1.00	WOOD FRAME [100%]			

BLDG COMMENTS

LOADING

YEAR BLT	2009	SIZE ADJ	1.000	ELEMENT	CD	DESCRIPTION	ADJ	S	BAT	T	DESCRIPTION	UNITS	YB	ADJ PRICE	RCN	TOTAL RCN	1,045,913
NET AREA	38,424	DETAIL ADJ	0.547	FOUNDATION	2	SLAB	1.00	+	LLF	L	LOW-LEV FIN	12,744	2009	17.82	227,040	CONDITION ELEM	CD
\$NLA(RCN)	\$27	OVERALL	1.015	EXT. COVER	2	CLAPBOARD	1.00	+	BAS	L	BASE AREA	12,744	2009	31.28	398,596	EXTERIOR	A
				ROOF SHAPE	1	GABLE	1.00	C	OPA	N	OPEN PORCH	18		17.99	324	INTERIOR	A
				ROOF COVER	1	ASPH/CMP SHIN	1.00	+	USF	L	UP-STRY FIN	12,936	2009	26.52	343,102	CDN/APP	A
				FLOOR COVER	5	VINYL	1.00		ELP	O	PASSGR. ELEV.	2		38,425.85	76,852		
				INT. FINISH	2	DRYWALL	1.00										
				HEATING/COOL	9	WARM/COOL AIR	1.00										
				FUEL SOURCE	2	GAS	1.00										
				NAF	0		1.00										
CAPACITY		UNITS	ADJ														
STORIES		2	1.00														
% HEATED		100	1.00														
% AIR COND		100	1.03														
% SPINKLERS		100	1.02														
EFF.YR/AGE		2009 / 13															
COND		13 13 %															
FUNC		0															
ECON		0															
DEPR		13 % GD 87															
RCNLD		\$909,900															

Key: 7358

Town of Bourne - Fiscal Year 2024

12/18/2023 6:02 pm SEQ #: 7.506

LEGAL

CURRENT OWNER		PARCEL ID	LOCATION			
HAC LLC 920 MAIN STREET, SUITE 115 KANSAS CITY, MO 64105		35.0-51-0	100 HARMONY HILL			
TRANSFER HISTORY		DOS	T	SALE PRICE	BK-PG (Cert)	

CLASS	CLASS%	DESCRIPTION			BN ID	BN	CARD	
1140	100	AFFORDABLE HSG UNITS				2	2 of 13	
PMT NO	PMT DT	TY	DESC	AMOUNT	INSP	BY	1st	%

LAND

CD	T	AC/SF/UN	Nbhd	Infl1	N Index	ADJ BASE	SAF	Topo	Lpi	VC	CREDIT AMT	ADJ VALUE

TOTAL	ZONING	FRNT	ASSESSED	CURRENT	PREVIOUS
Nbhd	NOTE		LAND	1,089,400	
Infl1		BUILDING			
N_Index		DETACHED			
			OTHER		
			TOTAL		

DETACHED

TY	QUAL	COND	DIM/NOTE	YB	UNITS	ADJ PRICE	RCNLD

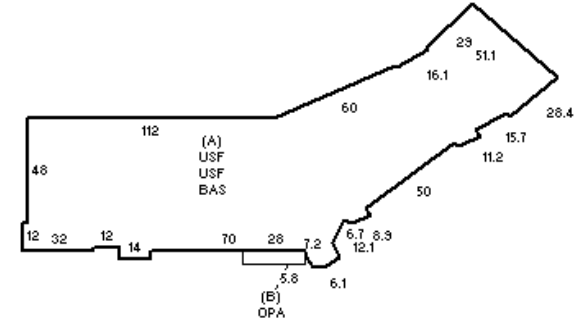

BUILDING

BUILDING	CD	ADJ	DESC	MEASURE	5/13/2019	RP
MODEL	5		CIM-5	LIST	4/8/2019	RP
STYLE	14	0.56	APARTMENTS HH [100%]	REVIEW	5/21/2019	BC
QUALITY	G	1.10	GOOD [100%]			
FRAME	1	1.00	WOOD FRAME [100%]			

BLDG COMMENTS

YEAR BLT	2012	SIZE ADJ	1.000	ELEMENT	CD	DESCRIPTION	ADJ	S	BAT	T	DESCRIPTION	UNITS	YB	ADJ PRICE	RCN	TOTAL RCN	1,210,451		
NET AREA	41,520	DETAIL ADJ	0.547	FOUNDATION	3	FOUND. WALL	1.00	A	BAS	L	BASE AREA	13,482	2012	31.24	421,163	CONDITION ELEM	CD		
\$NLA(RCN)	\$29	OVERALL	1.015	EXT. COVER	2	CLAPBOARD	1.00	A	USF	L	UP-STRY FIN	26,964	2012	26.49	714,292	EXTERIOR	A		
				ROOF SHAPE	1	GABLE	1.00	B	OPA	N	OPEN PORCH	168		17.97	3,020	INTERIOR	A		
				ROOF COVER	1	ASPH/CMP SHIN	1.00		BAS	L	BASE AREA	1,074	2012	31.24	33,551	CDN/APP	A		
				FLOOR COVER	5	VINYL	1.00		ELP	O	PASSGR. ELEV.	1		38,425.90	38,426				
				INT. FINISH	2	DRYWALL	1.00												
				HEATING/COOL	9	WARM/COOL AIR	1.00												
				FUEL SOURCE	2	GAS	1.00												
				NAF	0		1.00												
																		EFF.YR/AGE	2012 / 10
																		COND	10 10 %
																		FUNC	0
																		ECON	0
																		DEPR	10 % GD 90
																		RCNLD	\$1,089,400

Key: 7358

Town of Bourne - Fiscal Year 2024

12/18/2023 6:02 pm SEQ #: 7.507

LEGAL

CURRENT OWNER						PARCEL ID			LOCATION			
HAC LLC 920 MAIN STREET, SUITE 115 KANSAS CITY, MO 64105						35.0-51-0			100 HARMONY HILL			
TRANSFER HISTORY						DOS	T	SALE PRICE	BK-PG (Cert)			

CLASS	CLASS%	DESCRIPTION			BN ID	BN	CARD	
1140	100	AFFORDABLE HSG UNITS				3	3 of 13	
PMT NO	PMT DT	TY	DESC	AMOUNT	INSP	BY	1st	%

LAND

CD	T	AC/SF/UN	Nbhd	Infl1	N Index	ADJ BASE	SAF	Topo	Lpi	VC	CREDIT AMT	ADJ VALUE
----	---	----------	------	-------	---------	----------	-----	------	-----	----	------------	-----------

DETACHED

TOTAL	ZONING	FRNT	ASSESSED	CURRENT	PREVIOUS
Nbhd	NOTE		LAND	33,000	
Infl1			BUILDING		
N_Index			DETACHED		
			OTHER		
			TOTAL		

TY	QUAL	COND	DIM/NOTE	YB	UNITS	ADJ PRICE	RCNLD
----	------	------	----------	----	-------	-----------	-------

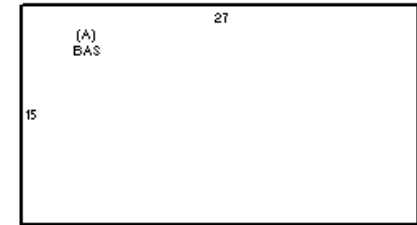

BUILDING

BUILDING	CD	ADJ	DESC	MEASURE	5/13/2019	RP
MODEL	5		CIM-5	LIST	5/13/2019	EST
STYLE	58	1.00	UTILITY BLD [100%]	REVIEW	5/21/2019	BC
QUALITY	G	1.10	GOOD [100%]			
FRAME	1	1.00	WOOD FRAME [100%]			

BLDG COMMENTS

YEAR BLT	2012	SIZE ADJ	1.000	ELEMENT	CD	DESCRIPTION	ADJ
NET AREA	405	DETAIL ADJ	0.766	FOUNDATION	2	SLAB	1.00
\$NLA(RCN)	\$91	OVERALL	1.000	EXT. COVER	2	CLAPBOARD	1.00
CAPACITY		UNITS	ADJ	ROOF SHAPE	1	GABLE	1.00
STORIES	1	1.00		ROOF COVER	1	ASPH/CMP SHIN	1.00
% HEATED	0	.95		FLOOR COVER	9	CONCRETE	0.95
% AIR COND	0	1.00		INT. FINISH	6	MINIMUM	0.95
% SPINKLERS	0	1.00		HEATING/COOL	13	NONE	0.95
				FUEL SOURCE	2	GAS	1.00
				NAF	0		1.00

S	BAT	T	DESCRIPTION	UNITS	YB	ADJ PRICE	RCN
A	BAS	L	BASE AREA	405	2012	90.62	36,702

TOTAL RCN	36,702
CONDITION ELEM	CD
EXTERIOR	A
INTERIOR	A
CDN/APP	A
EFF.YR/AGE	2012 / 10
COND	10 10 %
FUNC	0
ECON	0
DEPR	10 % GD 90
RCNLD	\$33,000

Key: 7358

Town of Bourne - Fiscal Year 2024

12/18/2023 6:02 pm SEQ #: 7.508

LEGAL

CURRENT OWNER		PARCEL ID	LOCATION			
HAC LLC 920 MAIN STREET, SUITE 115 KANSAS CITY, MO 64105		35.0-51-0	100 HARMONY HILL			
TRANSFER HISTORY		DOS	T	SALE PRICE	BK-PG (Cert)	

CLASS	CLASS%	DESCRIPTION			BN ID	BN	CARD
1140	100	AFFORDABLE HSG UNITS				4	4 of 13
PMT NO	PMT DT	TY	DESC	AMOUNT	INSP	BY	1st %

LAND

CD	T	AC/SF/UN	Nbhd	Infl1	N Index	ADJ BASE	SAF	Topo	Lpi	VC	CREDIT AMT	ADJ VALUE

DETACHED

TOTAL	ZONING	FRNT	ASSESSED	CURRENT	PREVIOUS
Nbhd	NOTE		LAND BUILDING DETACHED OTHER TOTAL	157,700	
Infl1					
N_Index					

TY	QUAL	COND	DIM/NOTE	YB	UNITS	ADJ PRICE	RCNLD

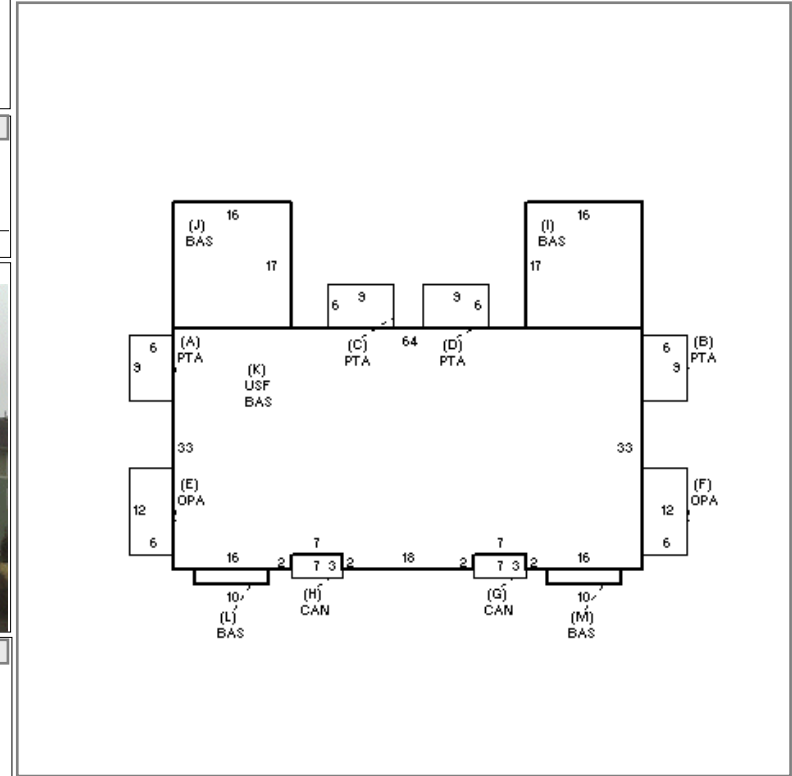

BUILDING

BUILDING	CD	ADJ	DESC	MEASURE	5/14/2019	RP
MODEL	5		CIM-5	LIST	5/14/2019	EST
STYLE	14	0.56	APARTMENTS HH [100%]	REVIEW	5/21/2019	BC
QUALITY	G	1.10	GOOD [100%]			
FRAME	1	1.00	WOOD FRAME [100%]			

BLDG COMMENTS

G

YEAR BLT	2017	SIZE ADJ	1.000	ELEMENT	CD	DESCRIPTION	ADJ	S	BAT	T	DESCRIPTION	UNITS	YB	ADJ PRICE	RCN	TOTAL RCN	166,017
NET AREA	4,752	DETAIL ADJ	0.547	FOUNDATION	2	SLAB	1.00	A	PTA	N	PATIO	54		4.14	223		
\$NLA(RCN)	\$35	OVERALL	1.015	EXT. COVER	2	CLAPBOARD	1.00	B	PTA	N	PATIO	54		4.14	223		
				ROOF SHAPE	1	GABLE	1.00	C	PTA	N	PATIO	54		4.14	223		
				ROOF COVER	1	ASPH/CMP SHIN	1.00	D	PTA	N	PATIO	54		4.14	223		
				FLOOR COVER	3	W/W CARPET	1.00	+	OPA	N	OPEN PORCH	144		17.97	2,588		
				INT. FINISH	2	DRYWALL	1.00	G	CAN	N	CANOPY	21		14.50	305		
				HEATING/COOL	9	WARM/COOL AIR	1.00	H	CAN	N	CANOPY	21		14.50	305		
				FUEL SOURCE	2	GAS	1.00	+	BAS	L	BASE AREA	2,668	2017	36.51	97,407		
				NAF	0		1.00	K	USF	L	UP-STRY FIN	2,084	2017	30.96	64,520		
																CONDITION ELEM	CD
																EXTERIOR	A
																INTERIOR	A
																CDN/APP	A
																EFF.YR/AGE	2017 / 5
																COND	5 5 %
																FUNC	0
																ECON	0
																DEPR	5 % GD 95
																RCNLD	\$157,700

Key: 7358

Town of Bourne - Fiscal Year 2024

12/18/2023 6:02 pm SEQ #: 7.509

LEGAL

CURRENT OWNER		PARCEL ID		LOCATION	
HAC LLC 920 MAIN STREET, SUITE 115 KANSAS CITY, MO 64105		35.0-51-0		100 HARMONY HILL	
TRANSFER HISTORY		DOS	T	SALE PRICE	BK-PG (Cert)

CLASS	CLASS%	DESCRIPTION			BN ID	BN	CARD
1140	100	AFFORDABLE HSG UNITS				5	5 of 13
PMT NO	PMT DT	TY	DESC	AMOUNT	INSP	BY	1st %

LAND

CD	T	AC/SF/UN	Nbhd	Infl1	N Index	ADJ BASE	SAF	Topo	Lpi	VC	CREDIT AMT	ADJ VALUE

TOTAL	ZONING	FRNT	ASSESSED	CURRENT	PREVIOUS
Nbhd	NOTE		LAND BUILDING DETACHED OTHER TOTAL	153,600	
Infl1					
N_Index					

DETACHED

TY	QUAL	COND	DIM/NOTE	YB	UNITS	ADJ PRICE	RCNLD

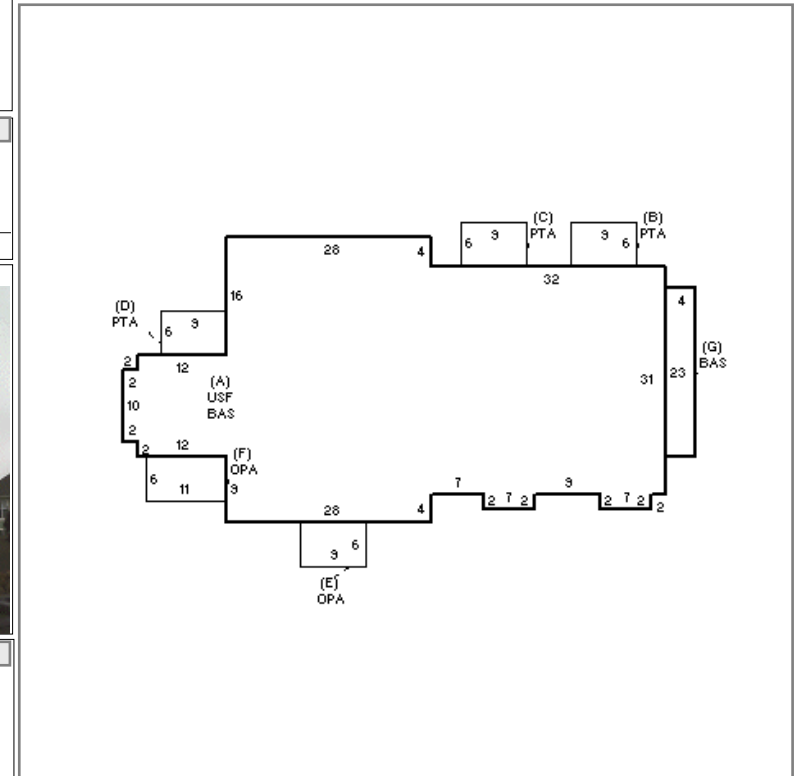

BUILDING

BUILDING	CD	ADJ	DESC	MEASURE	5/14/2019	RP
MODEL	5		CIM-5	LIST	5/14/2019	EST
STYLE	14	0.56	APARTMENTS HH [100%]	REVIEW	5/21/2019	BC
QUALITY	G	1.10	GOOD [100%]			
FRAME	1	1.00	WOOD FRAME [100%]			

BLDG COMMENTS

BUILDING

YEAR BLT	2017	SIZE ADJ	1.000	ELEMENT	CD	DESCRIPTION	ADJ	S	BAT	T	DESCRIPTION	UNITS	YB	ADJ PRICE	RCN	TOTAL RCN	161,696
NET AREA	4,692	DETAIL ADJ	0.547	FOUNDATION	2	SLAB	1.00	+	BAS	L	BASE AREA	2,392	2017	36.59	87,512		
\$NLA(RCN)	\$34	OVERALL	1.015	EXT. COVER	2	CLAPBOARD	1.00	A	USF	L	UP-STRY FIN	2,300	2017	31.02	71,357		
				ROOF SHAPE	1	GABLE	1.00	B	PTA	N	PATIO	54		4.14	223		
				ROOF COVER	1	ASPH/CMP SHIN	1.00	C	PTA	N	PATIO	54		4.14	223		
				FLOOR COVER	3	W/W CARPET	1.00	D	PTA	N	PATIO	54		4.14	223		
				INT. FINISH	2	DRYWALL	1.00	+	OPA	N	OPEN PORCH	120		17.97	2,157		
				HEATING/COOL	9	WARM/COOL AIR	1.00										
				FUEL SOURCE	2	GAS	1.00										
				NAF	0		1.00										
																CONDITION ELEM	CD
																EXTERIOR	A
																INTERIOR	A
																CDN/APP	A
																EFF.YR/AGE	2017 / 5
																COND	5 5 %
																FUNC	0
																ECON	0
																DEPR	5 % GD 95
																RCNLD	\$153,600

Key: 7358

Town of Bourne - Fiscal Year 2024

12/18/2023 6:02 pm SEQ #: 7.511

LEGAL

CURRENT OWNER		PARCEL ID		LOCATION	
HAC LLC 920 MAIN STREET, SUITE 115 KANSAS CITY, MO 64105		35.0-51-0		100 HARMONY HILL	
TRANSFER HISTORY		DOS	T	SALE PRICE	BK-PG (Cert)

CLASS	CLASS%	DESCRIPTION			BN ID	BN	CARD	
1140	100	AFFORDABLE HSG UNITS				7	7 of 13	
PMT NO	PMT DT	TY	DESC	AMOUNT	INSP	BY	1st	%

LAND

CD	T	AC/SF/UN	Nbhd	Infl1	N Index	ADJ BASE	SAF	Topo	Lpi	VC	CREDIT AMT	ADJ VALUE
----	---	----------	------	-------	---------	----------	-----	------	-----	----	------------	-----------

TOTAL	ZONING	FRNT	ASSESSED	CURRENT	PREVIOUS
Nbhd	NOTE		LAND	212,100	
Infl1			BUILDING		
N_Index			DETACHED		
			OTHER		
			TOTAL		

DETACHED

TY	QUAL	COND	DIM/NOTE	YB	UNITS	ADJ PRICE	RCNLD
----	------	------	----------	----	-------	-----------	-------

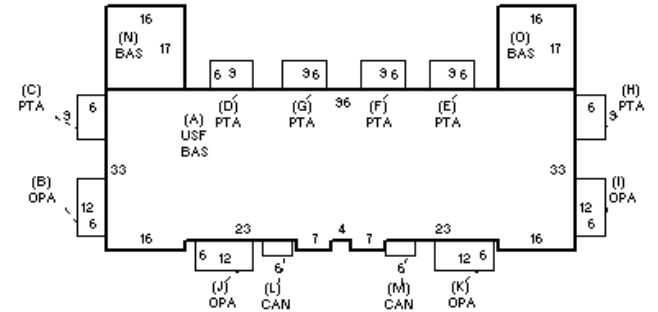

BUILDING

BUILDING	CD	ADJ	DESC	MEASURE	5/14/2019	RP
MODEL	5		CIM-5	LIST	5/14/2019	EST
STYLE	14	0.56	APARTMENTS HH [100%]	REVIEW	5/21/2019	BC
QUALITY	G	1.10	GOOD [100%]			
FRAME	1	1.00	WOOD FRAME [100%]			

BLDG COMMENTS

LOADING

YEAR BLT	2017	SIZE ADJ	1.000
NET AREA	6,680	DETAIL ADJ	0.547
\$NLA(RCN)	\$33	OVERALL	1.015
CAPACITY		UNITS	ADJ
STORIES	2	1.00	
% HEATED	100	1.00	
% AIR COND	100	1.03	
% SPINKLERS	100	1.02	

ELEMENT	CD	DESCRIPTION	ADJ	S	BAT	T	DESCRIPTION	UNITS	YB	ADJ PRICE	RCN
FOUNDATION	2	SLAB	1.00	+	BAS	L	BASE AREA	3,612	2017	34.79	125,663
EXT. COVER	2	CLAPBOARD	1.00	A	USF	L	UP-STRY FIN	3,068	2017	29.50	90,514
ROOF SHAPE	1	GABLE	1.00	+	OPA	N	OPEN PORCH	288		17.97	5,177
ROOF COVER	1	ASPH/CMP SHIN	1.00	C	PTA	N	PATIO	54		4.14	223
FLOOR COVER	3	W/W CARPET	1.00	D	PTA	N	PATIO	54		4.14	223
INT. FINISH	2	DRYWALL	1.00	E	PTA	N	PATIO	54		4.14	223
HEATING/COOL	9	WARM/COOL AIR	1.00	F	PTA	N	PATIO	54		4.14	223
FUEL SOURCE	2	GAS	1.00	G	PTA	N	PATIO	54		4.14	223
NAF	0		1.00	H	PTA	N	PATIO	54		4.14	223
				L	CAN	N	CANOPY	18		14.49	261
				M	CAN	N	CANOPY	18		14.49	261

TOTAL RCN	223,215
CONDITION ELEM	CD
EXTERIOR	A
INTERIOR	A
CDN/APP	A
EFF.YR/AGE	2017 / 5
COND	5 5 %
FUNC	0
ECON	0
DEPR	5 % GD 95
RCNLD	\$212,100

Key: 7358

Town of Bourne - Fiscal Year 2024

12/18/2023 6:02 pm SEQ #: 7.512

LEGAL

CURRENT OWNER		PARCEL ID	LOCATION			
HAC LLC 920 MAIN STREET, SUITE 115 KANSAS CITY, MO 64105		35.0-51-0	100 HARMONY HILL			
TRANSFER HISTORY		DOS	T	SALE PRICE	BK-PG (Cert)	

CLASS	CLASS%	DESCRIPTION			BN ID	BN	CARD
1140	100	AFFORDABLE HSG UNITS				8	8 of 13
PMT NO	PMT DT	TY	DESC	AMOUNT	INSP	BY	1st %

LAND

CD	T	AC/SF/UN	Nbhd	Infl1	N Index	ADJ BASE	SAF	Topo	Lpi	VC	CREDIT AMT	ADJ VALUE

TOTAL	ZONING	FRNT	ASSESSED	CURRENT	PREVIOUS
Nbhd	NOTE		LAND BUILDING DETACHED OTHER TOTAL	157,700	
Infl1					
N_Index					

DETACHED

TY	QUAL	COND	DIM/NOTE	YB	UNITS	ADJ PRICE	RCNLD	PHOTO
								05/14/2019

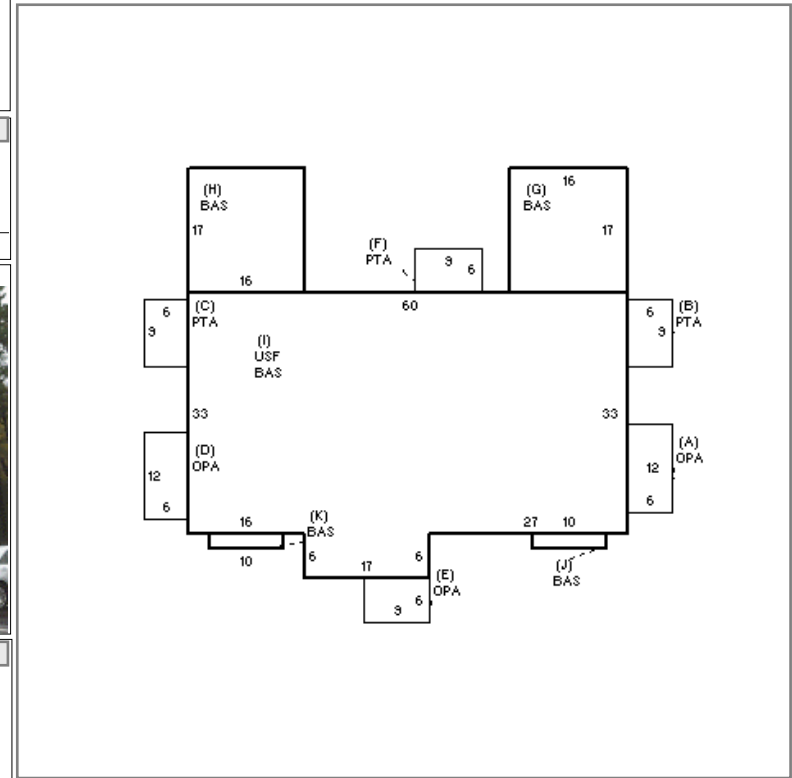

BUILDING

BUILDING	CD	ADJ	DESC	MEASURE	5/14/2019	RP
MODEL	5		CIM-5	LIST	5/14/2019	EST
STYLE	14	0.56	APARTMENTS HH [100%]	REVIEW	5/21/2019	BC
QUALITY	G	1.10	GOOD [100%]			
FRAME	1	1.00	WOOD FRAME [100%]			

BLDG COMMENTS

YEAR BLT	2017	SIZE ADJ	1.000	ELEMENT	CD	DESCRIPTION	ADJ	S	BAT	T	DESCRIPTION	UNITS	YB	ADJ PRICE	RCN	TOTAL RCN	166,021
NET AREA	4,748	DETAIL ADJ	0.547	FOUNDATION	2	SLAB	1.00	+	OPA	N	OPEN PORCH	198		17.98	3,560		
\$NLA(RCN)	\$35	OVERALL	1.015	EXT. COVER	2	CLAPBOARD	1.00	B	PTA	N	PATIO	54		4.14	223		
				ROOF SHAPE	1	GABLE	1.00	C	PTA	N	PATIO	54		4.14	223		
				ROOF COVER	1	ASPH/CMP SHIN	1.00	F	PTA	N	PATIO	54		4.14	223		
				FLOOR COVER	3	W/W CARPET	1.00	+	BAS	L	BASE AREA	2,666	2017	36.51	97,333		
				INT. FINISH	2	DRYWALL	1.00	I	USF	L	UP-STRY FIN	2,082	2017	30.96	64,458		
				HEATING/COOL	9	WARM/COOL AIR	1.00										
				FUEL SOURCE	2	GAS	1.00										
				NAF	0		1.00										
																CONDITION ELEM	CD
																EXTERIOR	A
																INTERIOR	A
																CDN/APP	A
																EFF.YR/AGE	2017 / 5
																COND	5 5 %
																FUNC	0
																ECON	0
																DEPR	5 % GD 95
																RCNLD	\$157,700

Key: 7358

Town of Bourne - Fiscal Year 2024

12/18/2023 6:02 pm SEQ #: 7.513

LEGAL

LAND

DETACHED

BUILDING

CURRENT OWNER		PARCEL ID	LOCATION		
HAC LLC 920 MAIN STREET, SUITE 115 KANSAS CITY, MO 64105		35.0-51-0	100 HARMONY HILL		
TRANSFER HISTORY		DOS	T	SALE PRICE	BK-PG (Cert)

CLASS	CLASS%	DESCRIPTION			BN ID	BN	CARD	
1140	100	AFFORDABLE HSG UNITS				9	9 of 13	
PMT NO	PMT DT	TY	DESC	AMOUNT	INSP	BY	1st	%

CD	T	AC/SF/UN	Nbhd	Infl1	N Index	ADJ BASE	SAF	Topo	Lpi	VC	CREDIT AMT	ADJ VALUE

TOTAL	ZONING	FRNT	ASSESSED	CURRENT	PREVIOUS
			LAND BUILDING DETACHED OTHER TOTAL	157,200	

TY	QUAL	COND	DIM/NOTE	YB	UNITS	ADJ PRICE	RCNLD

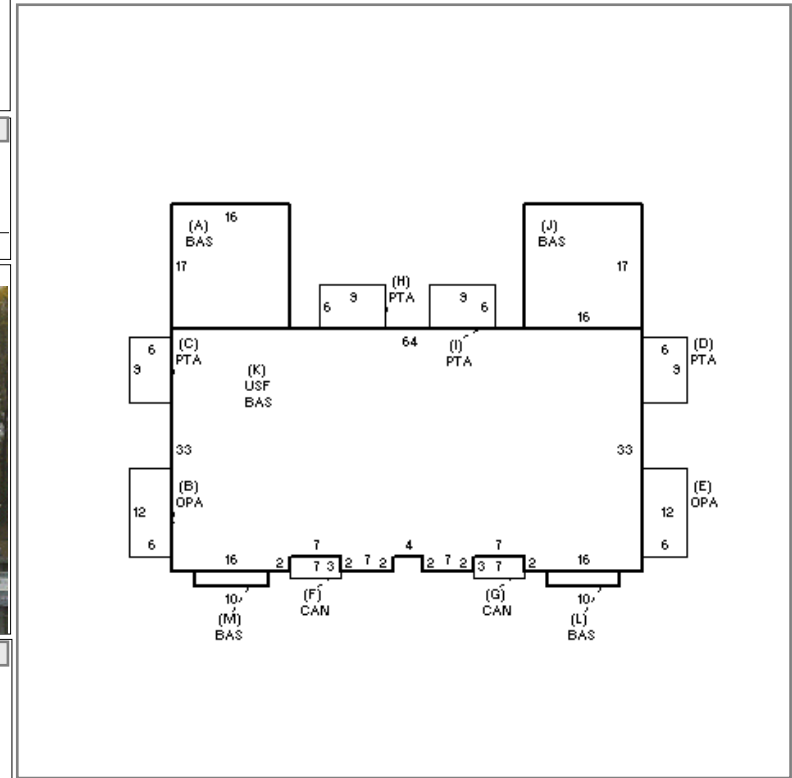

BUILDING	CD	ADJ	DESC	MEASURE	5/14/2019	RP
MODEL	5		CIM-5	LIST	5/14/2019	EST
STYLE	14	0.56	APARTMENTS HH [100%]	REVIEW	5/21/2019	BC
QUALITY	G	1.10	GOOD [100%]			
FRAME	1	1.00	WOOD FRAME [100%]			

BLDG COMMENTS

YEAR BLT	2017	SIZE ADJ	1.000	ELEMENT	CD	DESCRIPTION	ADJ	S	BAT	T	DESCRIPTION	UNITS	YB	ADJ PRICE	RCN	TOTAL RCN	165,477
NET AREA	4,736	DETAIL ADJ	0.547	FOUNDATION	2	SLAB	1.00	+	BAS	L	BASE AREA	2,660	2017	36.51	97,114		
\$NLA(RCN)	\$35	OVERALL	1.015	EXT. COVER	2	CLAPBOARD	1.00	+	OPA	N	OPEN PORCH	144		17.97	2,588		
CAPACITY		UNITS	ADJ	ROOF SHAPE	1	GABLE	1.00	C	PTA	N	PATIO	54		4.14	223		
STORIES	2	1.00		ROOF COVER	1	ASPH/CMP SHIN	1.00	D	PTA	N	PATIO	54		4.14	223		
% HEATED	100	1.00		FLOOR COVER	3	W/W CARPET	1.00	F	CAN	N	CANOPY	21		14.50	305		
% AIR COND	100	1.03		INT. FINISH	2	DRYWALL	1.00	G	CAN	N	CANOPY	21		14.50	305		
% SPINKLERS	100	1.02		HEATING/COOL	9	WARM/COOL AIR	1.00	H	PTA	N	PATIO	54		4.14	223		
				FUEL SOURCE	2	GAS	1.00	I	PTA	N	PATIO	54		4.14	223		
				NAF	0		1.00	K	USF	L	UP-STRY FIN	2,076	2017	30.96	64,272		
																CONDITION ELEM	CD
																EXTERIOR	A
																INTERIOR	A
																CDN/APP	A
																EFF.YR/AGE	2017 / 5
																COND	5 5 %
																FUNC	0
																ECON	0
																DEPR	5 % GD 95
																RCNLD	\$157,200

Key: 7358

Town of Bourne - Fiscal Year 2024

12/18/2023 6:02 pm SEQ #: 7.514

LEGAL

CURRENT OWNER		PARCEL ID	LOCATION			
HAC LLC 920 MAIN STREET, SUITE 115 KANSAS CITY, MO 64105		35.0-51-0	100 HARMONY HILL			
TRANSFER HISTORY		DOS	T	SALE PRICE	BK-PG (Cert)	

CLASS	CLASS%	DESCRIPTION			BN ID	BN	CARD	
1140	100	AFFORDABLE HSG UNITS				10	10 of 13	
PMT NO	PMT DT	TY	DESC	AMOUNT	INSP	BY	1st	%

LAND

CD	T	AC/SF/UN	Nbhd	Infl1	N Index	ADJ BASE	SAF	Topo	Lpi	VC	CREDIT AMT	ADJ VALUE

TOTAL	ZONING	FRNT	ASSESSED	CURRENT	PREVIOUS
Nbhd	NOTE		LAND BUILDING DETACHED OTHER TOTAL	157,200	
Infl1					
N_Index					

DETACHED

TY	QUAL	COND	DIM/NOTE	YB	UNITS	ADJ PRICE	RCNLD

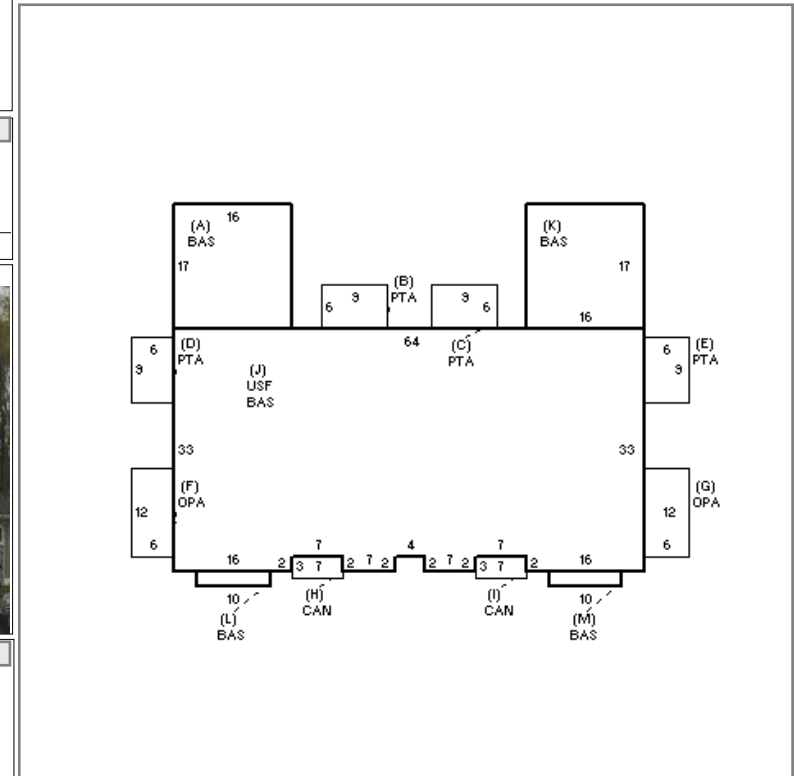

BUILDING

BUILDING	CD	ADJ	DESC	MEASURE	5/14/2019	RP
MODEL	5		CIM-5	LIST	5/14/2019	EST
STYLE	14	0.56	APARTMENTS HH [100%]	REVIEW	5/21/2019	BC
QUALITY	G	1.10	GOOD [100%]			
FRAME	1	1.00	WOOD FRAME [100%]			

BLDG COMMENTS

G

YEAR BLT	2017	SIZE ADJ	1.000	ELEMENT	CD	DESCRIPTION	ADJ	S	BAT	T	DESCRIPTION	UNITS	YB	ADJ PRICE	RCN	TOTAL RCN	165,477		
NET AREA	4,736	DETAIL ADJ	0.547	FOUNDATION	2	SLAB	1.00	+	BAS	L	BASE AREA	2,660	2017	36.51	97,114				
\$NLA(RCN)	\$35	OVERALL	1.015	EXT. COVER	2	CLAPBOARD	1.00	B	PTA	N	PATIO	54		4.14	223				
				ROOF SHAPE	1	GABLE	1.00	C	PTA	N	PATIO	54		4.14	223				
				ROOF COVER	1	ASPH/CMP SHIN	1.00	D	PTA	N	PATIO	54		4.14	223				
				FLOOR COVER	3	W/W CARPET	1.00	E	PTA	N	PATIO	54		4.14	223				
				INT. FINISH	2	DRYWALL	1.00	+	OPA	N	OPEN PORCH	144		17.97	2,588				
				HEATING/COOL	9	WARM/COOL AIR	1.00	H	CAN	N	CANOPY	21		14.50	305				
				FUEL SOURCE	2	GAS	1.00	I	CAN	N	CANOPY	21		14.50	305				
				NAF	0		1.00	J	USF	L	UP-STRY FIN	2,076	2017	30.96	64,272				
CAPACITY		UNITS	ADJ															TOTAL RCN	165,477
STORIES		2	1.00															CONDITION ELEM	CD
% HEATED		100	1.00															EXTERIOR	A
% AIR COND		100	1.03															INTERIOR	A
% SPINKLERS		100	1.02															CDN/APP	A
EFF. YR/AGE		2017 / 5																COND	5 5 %
FUNC		0																FUNC	0
ECON		0																ECON	0
DEPR		5 % GD																DEPR	95
RCNLD																		RCNLD	\$157,200

Key: 7358

Town of Bourne - Fiscal Year 2024

12/18/2023 6:02 pm SEQ #: 7.515

LEGAL

CURRENT OWNER		PARCEL ID	LOCATION		
HAC LLC 920 MAIN STREET, SUITE 115 KANSAS CITY, MO 64105		35.0-51-0	100 HARMONY HILL		
TRANSFER HISTORY		DOS	T	SALE PRICE	BK-PG (Cert)

CLASS	CLASS%	DESCRIPTION			BN ID	BN	CARD	
1140	100	AFFORDABLE HSG UNITS				11	11 of 13	
PMT NO	PMT DT	TY	DESC	AMOUNT	INSP	BY	1st	%

LAND

CD	T	AC/SF/UN	Nbhd	Infl1	N Index	ADJ BASE	SAF	Topo	Lpi	VC	CREDIT AMT	ADJ VALUE

TOTAL	ZONING	FRNT	ASSESSED	CURRENT	PREVIOUS
Nbhd	NOTE		LAND BUILDING DETACHED OTHER TOTAL	157,200	
Infl1					
N_Index					

DETACHED

TY	QUAL	COND	DIM/NOTE	YB	UNITS	ADJ PRICE	RCNLD

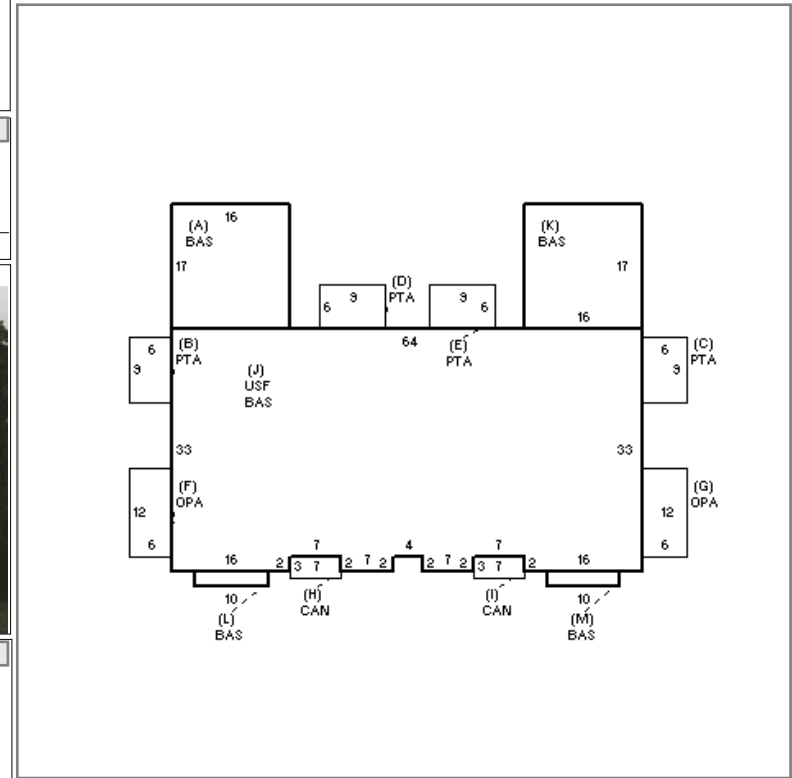

BLDG COMMENTS

BUILDING

BUILDING	CD	ADJ	DESC	MEASURE	5/14/2019	RP
MODEL	5		CIM-5	LIST	5/14/2019	EST
STYLE	14	0.56	APARTMENTS HH [100%]	REVIEW	5/21/2019	BC
QUALITY	G	1.10	GOOD [100%]			
FRAME	1	1.00	WOOD FRAME [100%]			

YEAR BLT	2017	SIZE ADJ	1.000	ELEMENT	CD	DESCRIPTION	ADJ	S	BAT	T	DESCRIPTION	UNITS	YB	ADJ PRICE	RCN	TOTAL RCN	165,477
NET AREA	4,736	DETAIL ADJ	0.547	FOUNDATION	2	SLAB	1.00	+	BAS	L	BASE AREA	2,660	2017	36.51	97,114		
\$NLA(RCN)	\$35	OVERALL	1.015	EXT. COVER	2	CLAPBOARD	1.00	B	PTA	N	PATIO	54		4.14	223		
				ROOF SHAPE	1	GABLE	1.00	C	PTA	N	PATIO	54		4.14	223		
				ROOF COVER	1	ASPH/CMP SHIN	1.00	D	PTA	N	PATIO	54		4.14	223		
				FLOOR COVER	3	W/W CARPET	1.00	E	PTA	N	PATIO	54		4.14	223		
				INT. FINISH	2	DRYWALL	1.00	+	OPA	N	OPEN PORCH	144		17.97	2,588		
				HEATING/COOL	9	WARM/COOL AIR	1.00	H	CAN	N	CANOPY	21		14.50	305		
				FUEL SOURCE	2	GAS	1.00	I	CAN	N	CANOPY	21		14.50	305		
				NAF	0		1.00	J	USF	L	UP-STRY FIN	2,076	2017	30.96	64,272		
																CONDITION ELEM	CD
																EXTERIOR	A
																INTERIOR	A
																CDN/APP	A
																EFF.YR/AGE	2017 / 5
																COND	5 5 %
																FUNC	0
																ECON	0
																DEPR	5 % GD 95
																RCNLD	\$157,200

Key: 7358

Town of Bourne - Fiscal Year 2024

12/18/2023 6:02 pm SEQ #: 7.516

LEGAL

CURRENT OWNER		PARCEL ID		LOCATION	
HAC LLC 920 MAIN STREET, SUITE 115 KANSAS CITY, MO 64105		35.0-51-0		100 HARMONY HILL	
TRANSFER HISTORY		DOS	T	SALE PRICE	BK-PG (Cert)

CLASS	CLASS%	DESCRIPTION			BN ID	BN	CARD	
1140	100	AFFORDABLE HSG UNITS				12	12 of 13	
PMT NO	PMT DT	TY	DESC	AMOUNT	INSP	BY	1st	%

LAND

CD	T	AC/SF/UN	Nbhd	Inf1	N Index	ADJ BASE	SAF	Topo	Lpi	VC	CREDIT AMT	ADJ VALUE
----	---	----------	------	------	---------	----------	-----	------	-----	----	------------	-----------

DETACHED

TOTAL	ZONING	FRNT	ASSESSED	CURRENT	PREVIOUS
Nbhd	NOTE		LAND BUILDING DETACHED OTHER TOTAL	157,700	
Inf1					
N_Index					

TY	QUAL	COND	DIM/NOTE	YB	UNITS	ADJ PRICE	RCNLD	PHOTO
								05/14/2019

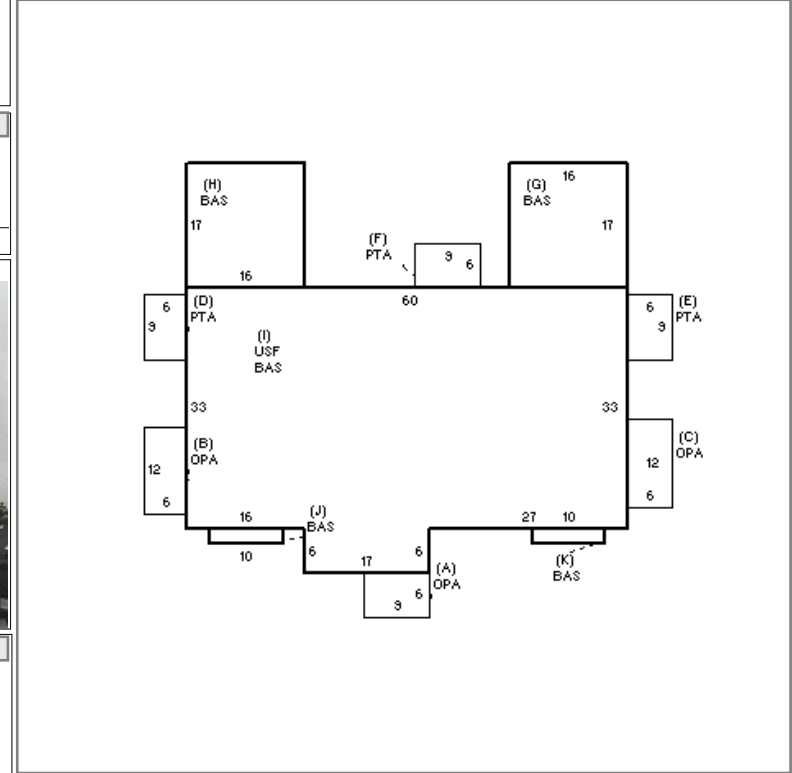

BUILDING

BUILDING	CD	ADJ	DESC	MEASURE	5/14/2019	RP
MODEL	5		CIM-5	LIST	5/14/2019	EST
STYLE	14	0.56	APARTMENTS HH [100%]	REVIEW	5/21/2019	BC
QUALITY	G	1.10	GOOD [100%]			
FRAME	1	1.00	WOOD FRAME [100%]			

BLDG COMMENTS

YEAR BLT	2017	SIZE ADJ	1.000	ELEMENT	CD	DESCRIPTION	ADJ	S	BAT	T	DESCRIPTION	UNITS	YB	ADJ PRICE	RCN	TOTAL RCN	166,021
NET AREA	4,748	DETAIL ADJ	0.547	FOUNDATION	2	SLAB	1.00	+	OPA	N	OPEN PORCH	198		17.98	3,560		
\$NLA(RCN)	\$35	OVERALL	1.015	EXT. COVER	2	CLAPBOARD	1.00	D	PTA	N	PATIO	54		4.14	223		
				ROOF SHAPE	1	GABLE	1.00	E	PTA	N	PATIO	54		4.14	223		
				ROOF COVER	1	ASPH/CMP SHIN	1.00	F	PTA	N	PATIO	54		4.14	223		
				FLOOR COVER	3	W/W CARPET	1.00	+	BAS	L	BASE AREA	2,666	2017	36.51	97,333		
				INT. FINISH	2	DRYWALL	1.00	I	USF	L	UP-STRY FIN	2,082	2017	30.96	64,458		
				HEATING/COOL	9	WARM/COOL AIR	1.00										
				FUEL SOURCE	2	GAS	1.00										
				NAF	0		1.00										
																CONDITION ELEM	CD
																EXTERIOR	A
																INTERIOR	A
																CDN/APP	A
																EFF.YR/AGE	2017 / 5
																COND	5 5 %
																FUNC	0
																ECON	0
																DEPR	5 % GD 95
																RCNLD	\$157,700

Key: 7358

Town of Bourne - Fiscal Year 2024

12/18/2023 6:02 pm SEQ #: 7.517

LEGAL LAND

CURRENT OWNER		PARCEL ID	LOCATION			
HAC LLC 920 MAIN STREET, SUITE 115 KANSAS CITY, MO 64105		35.0-51-0	100 HARMONY HILL			
TRANSFER HISTORY		DOS	T	SALE PRICE	BK-PG (Cert)	

CLASS	CLASS%	DESCRIPTION		BN ID	BN	CARD		
1140	100	AFFORDABLE HSG UNITS			13	13 of 13		
PMT NO	PMT DT	TY	DESC	AMOUNT	INSP	BY	1st	%

CD	T	AC/SF/UN	Nbhd	Inf1	N Index	ADJ BASE	SAF	Topo	Lpi	VC	CREDIT AMT	ADJ VALUE
----	---	----------	------	------	---------	----------	-----	------	-----	----	------------	-----------

TOTAL	ZONING	FRNT	ASSESSED	CURRENT	PREVIOUS
Nbhd	NOTE		LAND	212,100	
Inf1		BUILDING			
N_Index		DETACHED			
			OTHER		
			TOTAL		

TY	QUAL	COND	DIM/NOTE	YB	UNITS	ADJ PRICE	RCNLD
----	------	------	----------	----	-------	-----------	-------

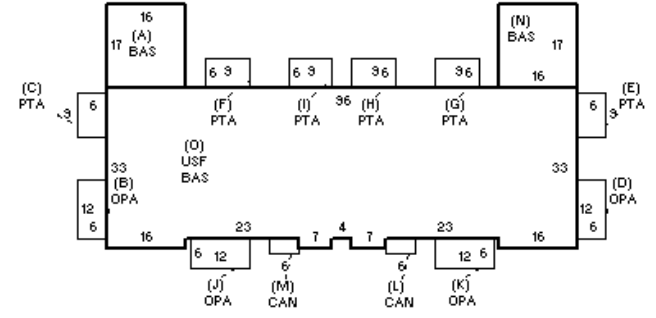

BLDG COMMENTS

DETACHED

BUILDING

BUILDING	CD	ADJ	DESC	MEASURE	5/14/2019	RP
MODEL	5		CIM-5	LIST	5/14/2019	EST
STYLE	14	0.56	APARTMENTS HH [100%]	REVIEW	5/21/2019	BC
QUALITY	G	1.10	GOOD [100%]			
FRAME	1	1.00	WOOD FRAME [100%]			

YEAR BLT	2017	SIZE ADJ	1.000
NET AREA	6,680	DETAIL ADJ	0.547
\$NLA(RCN)	\$33	OVERALL	1.015
CAPACITY		UNITS	ADJ
STORIES		2	1.00
% HEATED		100	1.00
% AIR COND		100	1.03
% SPINKLERS		100	1.02

ELEMENT	CD	DESCRIPTION	ADJ	S	BAT	T	DESCRIPTION	UNITS	YB	ADJ PRICE	RCN
FOUNDATION	2	SLAB	1.00	+	BAS	L	BASE AREA	3,612	2017	34.79	125,663
EXT. COVER	2	CLAPBOARD	1.00	+	OPA	N	OPEN PORCH	288		17.97	5,177
ROOF SHAPE	1	GABLE	1.00	C	PTA	N	PATIO	54		4.14	223
ROOF COVER	1	ASPH/CMP SHIN	1.00	E	PTA	N	PATIO	54		4.14	223
FLOOR COVER	3	W/W CARPET	1.00	F	PTA	N	PATIO	54		4.14	223
INT. FINISH	2	DRYWALL	1.00	G	PTA	N	PATIO	54		4.14	223
HEATING/COOL	9	WARM/COOL AIR	1.00	H	PTA	N	PATIO	54		4.14	223
FUEL SOURCE	2	GAS	1.00	I	PTA	N	PATIO	54		4.14	223
NAF	0		1.00	L	CAN	N	CANOPY	18		14.49	261
				M	CAN	N	CANOPY	18		14.49	261
				O	USF	L	UP-STRY FIN	3,068	2017	29.50	90,514

TOTAL RCN	223,215
CONDITION ELEM	CD
EXTERIOR	A
INTERIOR	A
CDN/APP	A
EFF.YR/AGE	2017 / 5
COND	5 5 %
FUNC	0
ECON	0
DEPR	5 % GD 95
RCNLD	\$212,100