

Key: 7387

Town of Bourne - Fiscal Year 2024

12/18/2023 6:02 pm SEQ #: 7.544

LEGALS

CURRENT OWNER				PARCEL ID				LOCATION			
BARCLAY THOMAS A & GEORGIANNA M BARCLAY 84 SPINNAKER LANE POCASSET, MA 02559-1912				35.0-111-0				84 SPINNAKER LN			
TRANSFER HISTORY				DOS	T	SALE PRICE	BK-PG (Cert)				
BARCLAY THOMAS A & PRIESTLY DONALD H TR				08/30/1996	QS	143,536	10370-166				
RAFS LIMITED PARTNERSHIP				06/29/1994	B	850,000	N/A-N/A				
				03/02/1994	B	100	N/A-N/A				

CLASS	CLASS%	DESCRIPTION			BN ID	BN	CARD	
1010	100	SINGLE FAMILY				1	1 of 1	
PMT NO	PMT DT	TY	DESC	AMOUNT	INSP	BY	1st	%
980087	02/26/1998	9	DECK	5,000	02/16/1999	JS	0	100
960234	05/28/1996	1	NEW CONSTRUC	80,000	02/03/1998	JS	0	100

LAND

CD	T	AC/SF/UN	Nbhd	Infl1	N Index	ADJ BASE	SAF	Topo	Lpi	VC	CREDIT AMT	ADJ VALUE					
100	S	18,268	11	1.00	100	1.00	100	1.00	235,700	1.84	A	1.00	R05	1.00			182,290

DETACHED

TOTAL	18,252 SF	ZONING	1	FRNT	0	ASSESSED	CURRENT	PREVIOUS
Nbhd	POC	NOTE	LAND	182,300	161,300			
Infl1	AVG		BUILDING	351,700	315,100			
N_Index	AVG		DETACHED	0	0			
			OTHER	0	0			
			TOTAL	534,000	476,400			

TY	QUAL	COND	DIM/NOTE	YB	UNITS	ADJ PRICE	RCNLD



BLDG COMMENTS

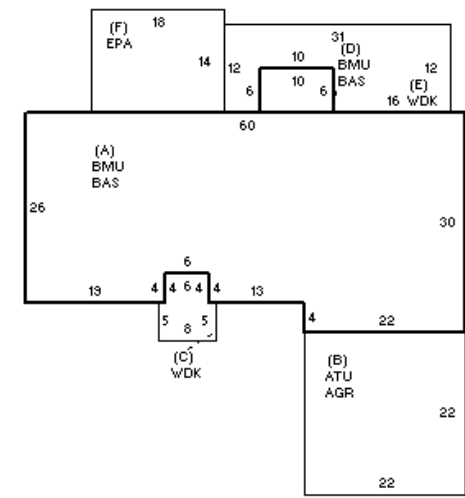

BUILDING

BUILDING	CD	ADJ	DESC	MEASURE	5/10/2000	EB
MODEL	1		RESIDENTIAL	LIST	5/10/2000	EBY
STYLE	1	0.95	RANCH [100%]	REVIEW	5/10/2000	EB
QUALITY	A	1.00	AVERAGE [100%]			
FRAME	1	1.00	WOOD FRAME [100%]			

YEAR BLT	1996	SIZE ADJ	1.010	ELEMENT	CD	DESCRIPTION	ADJ	S	BAT	T	DESCRIPTION	UNITS	YB	ADJ PRICE	RCN	TOTAL RCN	439,573
NET AREA	1,684	DETAIL ADJ	1.000	FOUNDATION	4	FLR/WALL(FULL)	1.00	+	BAS	L	BASE AREA	1,684	1996	182.36	307,098		
\$NLA(RCN)	\$261	OVERALL	1.000	EXT COVER	1	WOOD SHINGLE	1.02	+	BMU	N	BSMT UNFINISHED	1,684		29.95	50,433		
				ROOF SHAPE	1	GABLE	1.00	B	AGR	N	ATT GARAGE	484		62.42	30,213		
				ROOF COVER	1	ASPH/COMP SHIN	1.00	B	ATU	N	ATTIC UNF	484		42.69	20,662		
				FLOOR COVER	3	W/W CARPET	1.00	+	WDK	N	WOOD DECK	376		21.57	8,111		
				INT. FINISH	2	DRYWALL	1.00	F	EPA	N	ENCLOSED PORCH	252		65.89	16,603		
				HEATING/COOLING	9	WARM-COOL AIR	1.03		FIX	O	XTRA FIXTURES	3		2,150.97	6,453		
				FUEL SOURCE	2	GAS	1.00										
				USE	0		1.00										

CONDITION ELEM	CD
EXTERIOR	A
INTERIOR	A
KITCHEN	A
BATHS	A
HEAT	A
ELECT	A

EFF.YR/AGE	1999 / 23
COND	20 20 %
FUNC	0
ECON	0
DEPR	20 % GD 80
RCNLD	\$351,700