

Key: 7390

Town of Bourne - Fiscal Year 2024

12/18/2023 6:02 pm SEQ #: 7.547

LEGAL

CURRENT OWNER				PARCEL ID				LOCATION			
MEAL JOHN D 55 SPINNAKER LANE POCASSET, MA 02559-1911				35.0-114-0				55 SPINNAKER LN			
TRANSFER HISTORY				DOS	T	SALE PRICE	BK-PG (Cert)				
MEAL JOHN D				10/01/1999	QS	187,500	12579-257				
DEFILIPPIS ALESSANDRA M				12/29/1994	D	142,275	10819-253				
PRIESTLY DONALD H TR				06/29/1994	B	850,000	N/A-N/A				

CLASS	CLASS%	DESCRIPTION			BN ID	BN	CARD	
1010	100	SINGLE FAMILY				1	1 of 1	
PMT NO	PMT DT	TY	DESC	AMOUNT	INSP	BY	1st	%
12730	10/12/2012	3	ALT/RENO	7,000	03/13/2013		100	100
940431	08/31/1994	1	NEW CONSTRUC	65,000	02/16/1995	JS	100	100

LAND

CD	T	AC/SF/UN	Nbhd	Infl1	N Index	ADJ BASE	SAF	Topo	Lpi	VC	CREDIT AMT	ADJ VALUE					
100	S	19,610	11	1.00	100	1.00	100	1.00	235,700	1.74	A	1.00	R05	1.00			184,390

TOTAL	19,602 SF	ZONING	1	FRNT	0	ASSESSED	CURRENT	PREVIOUS
Nbhd	POC	NOTE	LAND	184,400	163,200			
Infl1	AVG		BUILDING	277,400	245,500			
N_Index	AVG		DETACHED	0	0			
			OTHER	0	0			
TOTAL				461,800	408,700			

DETACHED

TY	QUAL	COND	DIM/NOTE	YB	UNITS	ADJ PRICE	RCNLD	PHOTO	08/17/2002
									

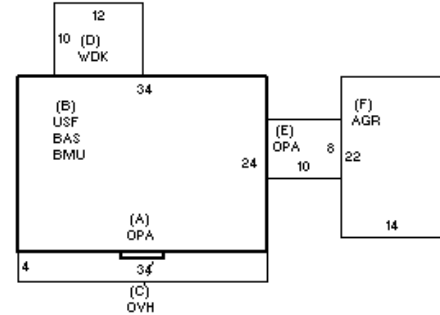

BUILDING

BUILDING	CD	ADJ	DESC	MEASURE	8/18/2002	TL
MODEL	1		RESIDENTIAL	LIST	2/16/1995	JS
STYLE	5	1.00	COLONIAL [100%]	REVIEW	3/13/2013	TL
QUALITY	A	1.00	AVERAGE [100%]			
FRAME	1	1.00	WOOD FRAME [100%]			

YEAR BLT	1994	SIZE ADJ	1.010	ELEMENT	CD	DESCRIPTION	ADJ	S	BAT	T	DESCRIPTION	UNITS	YB	ADJ PRICE	RCN	TOTAL RCN	346,737		
NET AREA	1,638	DETAIL ADJ	1.000	FOUNDATION	4	FLR/WALL(FULL)	1.00	+	OPA	N	OPEN PORCH	216		61.82	13,353				
\$NLA(RCN)	\$212	OVERALL	1.040	EXT COVER	2	CLAPBOARD	1.00	B	BMU	N	BSMT UNFINISHED	816		38.30	31,255				
				ROOF SHAPE	1	GABLE	1.00	B	BAS	L	BASE AREA	816	1994	208.30	169,972		A		
				ROOF COVER	1	ASPH/COMP SHIN	1.00	B	USF	L	UPPER STORY FIN	816	1994	113.08	92,270		A		
				FLOOR COVER	1	HARDWOOD	1.02	C	OVH	L	OVERHANG	6	1994	190.30	1,142		A		
				INT. FINISH	2	DRYWALL	1.00	D	WDK	N	WOOD DECK	120		41.51	4,981		A		
				HEATING/COOLING	2	HOT WATER	1.02	F	AGR	N	ATT GARAGE	308		73.31	22,580		A		
				FUEL SOURCE	2	GAS	1.00		FIX	O	XTRA FIXTURES	5		2,236.94	11,185		A		
				USE	0		1.00												
																EFF.YR/AGE	1999 / 23		
																COND	20 20 %		
																FUNC	0		
																ECON	0		
																DEPR	20	% GD	80
																RCNLD	\$277,400		