

Key: 7395

Town of Bourne - Fiscal Year 2024

12/18/2023 6:02 pm SEQ #: 7.552

LEGAL

LAND

DETACHED

BUILDING

CURRENT OWNER				PARCEL ID				LOCATION			
BURT THOMAS E 4 DANIEL WEBSTER LN POCASSET, MA 02559				35.0-119-0				4 DANIEL WEBSTER LN			
TRANSFER HISTORY				DOS	T	SALE PRICE	BK-PG (Cert)				
BURT THOMAS E				08/16/2010	QS	330,000	24755-50				
SMITH DEBORAH				09/12/2005	QS	420,000	20248-220				
DEXTER JEFFREY R				06/29/1998	QS	160,400	11532-1				

CLASS	CLASS%	DESCRIPTION			BN ID	BN	CARD	
1010	100	SINGLE FAMILY				1	1 of 1	
PMT NO	PMT DT	TY	DESC	AMOUNT	INSP	BY	1st	%
EXB-22-290	05/13/2022	14	SOLAR	16,800			100	100
EXB-22-177	03/30/2022	3	ALT/RENO	8,800			100	100
17038	01/12/2017	3	ALT/RENO	2,000			100	100
970598	11/25/1997	1	NEW CONSTRUCT	80,000	09/22/1999	MWS	100	100

CD	T	AC/SF/UN	Nbhd	Infl1	N Index	ADJ BASE	SAF	Topo	Lpi	VC	CREDIT AMT	ADJ VALUE					
100	S	16,370	11	1.00	100	1.00	100	1.00	235,700	2.02	A	1.00	R05	1.00			179,320

TOTAL	16,379 SF	ZONING	1	FRNT	0	ASSESSED	CURRENT	PREVIOUS
Nbhd	POC	NOTE	LAND	179,300	158,700			
Infl1	AVG		BUILDING	352,400	311,900			
N_Index	AVG		DETACHED	0	0			
			OTHER	0	0			
			<b>TOTAL</b>	<b>531,700</b>	<b>470,600</b>			

TY	QUAL	COND	DIM/NOTE	YB	UNITS	ADJ PRICE	RCNLD



BUILDING	CD	ADJ	DESC	MEASURE	8/23/2021	RP
MODEL	1		RESIDENTIAL	LIST	8/23/2021	EST
STYLE	5	1.00	COLONIAL [100%]	REVIEW	8/23/2021	
QUALITY	A	1.00	AVERAGE [100%]			
FRAME	1	1.00	WOOD FRAME [100%]			

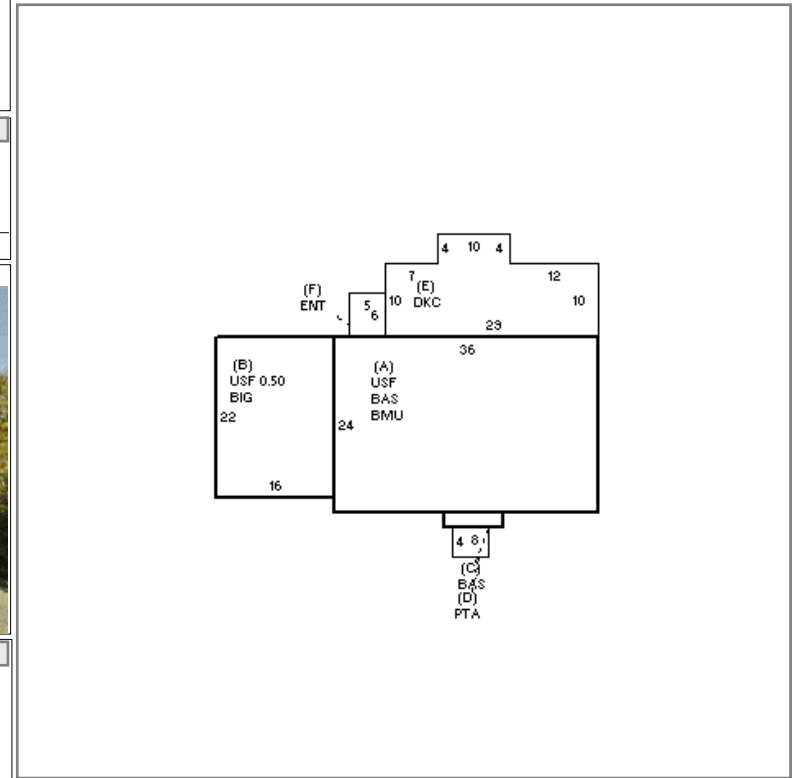

YEAR BLT	1998	SIZE ADJ	1.010
NET AREA	1,920	DETAIL ADJ	1.000
\$NLA(RCN)	\$224	OVERALL	1.060

CAPACITY	UNITS	ADJ
STORIES	2	1.00
ROOMS	6	1.00
BEDROOMS	3	1.00
BATHROOMS	2	1.00
FIXTURES	10	1.00
GARAGE CAPACITY	1	1.00
% BSMT FINISH	0	1.00
# OF HALF BATHS	1	1.00
# OF UNITS	1	1.00

ELEMENT	CD	DESCRIPTION	ADJ	S	BAT	T	DESCRIPTION	UNITS	YB	ADJ PRICE	RCN
FOUNDATION	4	FLR/WALL(FULL)	1.00	A	BMU	N	BSMT UNFINISHED	864		39.04	33,730
EXT COVER	1	WOOD SHINGLE	1.02	+	USF	L	UPPER STORY FIN	1,040	1998	111.31	115,761
ROOF SHAPE	1	GABLE	1.00	B	BIG	N	BUILT-IN GARAGE	352		94.79	33,367
ROOF COVER	1	ASPH/COMP SHIN	1.00	+	BAS	L	BASE AREA	880	1998	212.30	186,828
FLOOR COVER	1	HARDWOOD	1.02	D	PTA	N	PATIO	20		18.04	361
INT. FINISH	2	DRYWALL	1.00	E	DKC	N	DECK-COMPOSITE	330		67.22	22,183
HEATING/COOLING	2	HOT WATER	1.02	F	ENT	N	ENCLOSED ENTRY	30		90.50	2,715
FUEL SOURCE	2	GAS	1.00	B	MF	N	BSMT FINISH	500		46.91	23,454
USE	0		1.00		FIX	O	XTRA FIXTURES	5		2,279.94	11,400

TOTAL RCN	429,799
CONDITION ELEM	CD
EXTERIOR	A
INTERIOR	A
KITCHEN	A
BATHS	A
HEAT	A
ELECT	A

EFF.YR/AGE	2001 / 21
COND	18 18 %
FUNC	0
ECON	0
DEPR	18 % GD 82

RCNLD	\$352,400
-------	-----------