

Key: 7613

Town of Bourne - Fiscal Year 2024

12/18/2023 6:02 pm SEQ #: 7.769

LEGALS

CURRENT OWNER		PARCEL ID	LOCATION		
PIPER MADELINE G & MICHAEL WILLIAM FINNERAN 20 BRIGGS AVE BOURNE, MA 02532		35.2-60-0	20 BRIGGS AVE		
TRANSFER HISTORY		DOS	T	SALE PRICE	BK-PG (Cert)
PIPER MADELINE G & PIPER MADELINE G		05/17/2013	F	1	27384-182
REC ROGER H		05/15/2013	QS	252,000	27375-267
		06/20/2011	F	1	25515-308

CLASS	CLASS%	DESCRIPTION			BN ID	BN	CARD	
1010	100	SINGLE FAMILY				1	1 of 1	
PMT NO	PMT DT	TY	DESC	AMOUNT	INSP	BY	1st	%

LAND

CD	T	AC/SF/UN	Nbhd	Infl1	N Index	ADJ BASE	SAF	Topo	Lpi	VC	CREDIT AMT	ADJ VALUE					
100	S	13,080	9	1.00	100	1.00	100	1.00	235,700	2.46	A	1.00	R04	1.00			174,150

TOTAL	13,068 SF	ZONING	1	FRNT	0	ASSESSED	CURRENT	PREVIOUS
Nbhd	MO BCH	NOTE				LAND	174,200	154,100
Infl1	AVG		BUILDING	288,400	255,200			
N_Index	AVG		DETACHED	1,500	1,400			
			OTHER	0	0			
						<b>TOTAL</b>	<b>464,100</b>	<b>410,700</b>

DETACHED

TY	QUAL	COND	DIM/NOTE	YB	UNITS	ADJ PRICE	RCNLD
SHF	A	1.00	A 0.75 10X12		120	16.42	1,500

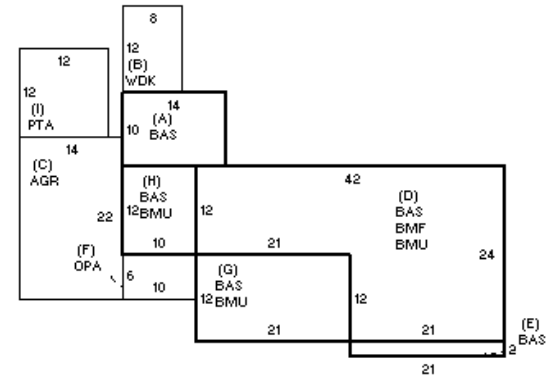

BUILDING

BUILDING	CD	ADJ	DESC	MEASURE	3/10/2017	DB
MODEL	1		RESIDENTIAL	LIST	3/10/2017	EST
STYLE	1	0.95	RANCH [100%]	REVIEW		
QUALITY	A	1.00	AVERAGE [100%]			
FRAME	1	1.00	WOOD FRAME [100%]			

BLDG COMMENTS

G

YEAR BLT	1979	SIZE ADJ	1.015	ELEMENT	CD	DESCRIPTION	ADJ	S	BAT	T	DESCRIPTION	UNITS	YB	ADJ PRICE	RCN	TOTAL RCN	365.031	
NET AREA	1,310	DETAIL ADJ	1.000	FOUNDATION	4	FLR/WALL(FULL)	1.00	+	BAS	L	BASE AREA	182	1979	188.90	34,379			
\$NLA(RCN)	\$279	OVERALL	0.990	EXT COVER	1	WOOD SHINGLE	1.02	B	WDK	N	WOOD DECK	96		44.21	4,245			
				ROOF SHAPE	1	GABLE	1.00	C	AGR	N	ATT GARAGE	308		70.13	21,601			
				ROOF COVER	1	ASPH/COMP SHIN	1.00	+	BMU	N	BSMT UNFINISHED	1,128		36.64	41,332			
				FLOOR COVER	13	HARDWOOD-W/W	1.00	D	BMF	N	BSMT FINISH	756		44.03	33,285			
				INT. FINISH	2	DRYWALL	1.00	+	BAS	L	BASE AREA	1,128	1979	188.89	213,071			
				HEATING/COOLING	2	HOT WATER	1.02	F	OPA	N	OPEN PORCH	60		77.01	4,620			
				FUEL SOURCE	1	OIL	1.00	I	PTA	N	PATIO	144		14.36	2,068			
				USE	0		1.00	FIX	O	XTRA FIXTURES	3		2,140.00	6,420				
								MST	O	MAS/METAL STACK	1		4,010.40	4,010				
																EFF.YR/AGE	1998 / 24	
																COND	21	21 %
																FUNC	0	
																ECON	0	
																DEPR	21	% GD 79
																RCNLD		\$288,400