

Key: 7702

Town of Bourne - Fiscal Year 2024

12/18/2023 6:02 pm SEQ #: 7.857

LEG
A
L

L
A
N
D

CURRENT OWNER				PARCEL ID				LOCATION			
GRAICHEN SCOTT & LAURA GRAY 37 BRADY AVE SALEM, NH 03079				37.0-8-0				4 MIDDLE WAY			
TRANSFER HISTORY				DOS	T	SALE PRICE	BK-PG (Cert)				
GRAICHEN SCOTT & HAZEL ELIZABETH T TR OF T				05/04/2012	QS	572,000	26307-198				
EARLEY THERESE M TR OF				10/02/2007	F		22380-73				
				09/12/1997	XX		10948-149				

CLASS	CLASS%	DESCRIPTION			BN ID	BN	CARD	
1010	100	SINGLE FAMILY				1	1 of 1	
PMT NO	PMT DT	TY	DESC	AMOUNT	INSP	BY	1st	%
14860	10/09/2014	2	ADDITIONS	16,000	11/12/2015	SW	100	100
14244	04/16/2014	15	INSULATE/WEA		08/11/2014		100	100
12732	10/15/2012	3	ALT/RENO		03/13/2013		100	100
910531	11/08/1991	2	ADDITIONS	50,000	09/09/1993	CP	100	100

CD	T	AC/SF/UN	Nbhd	Infl1	N Index	ADJ BASE	SAF	Topo	Lpi	VC	CREDIT AMT	ADJ VALUE					
100	S	12,730	11	1.00	100	1.00	100	1.00	942,800	2.52	A	1.00	BGD	4.00			694,400

TOTAL	12,720 SF	ZONING	1	FRNT	0	ASSESSED	CURRENT	PREVIOUS		
Nbhd	POC	NOTE	LAND		694,400	614,600	BUILDING		396,400	350,800
Infl1	AVG		DETACHED		2,100	2,000	OTHER		0	0
N_Index	AVG		TOTAL		1,092,900	967,400				

TY	QUAL	COND	DIM/NOTE	YB	UNITS	ADJ PRICE	RCNLD	
SHF	A	1.00	10 0.90	10 X 14		140	16.42	2,100

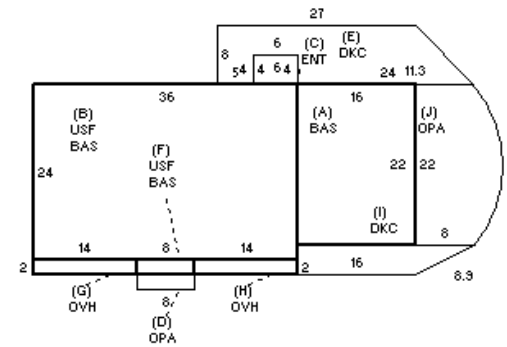

BUILDING	CD	ADJ	DESC	MEASURE	11/12/2015	SW
MODEL	1		RESIDENTIAL	LIST	11/12/2015	SW
STYLE	5	1.00	COLONIAL [100%]	REVIEW	10/25/2016	TL
QUALITY	+	1.05	AVERAGE + [100%]			
FRAME	1	1.00	WOOD FRAME [100%]			

BLDG COMMENTS

DE
T
A
C
H
E
D

B
U
I
L
D
I
N
G

YEAR BLT	1961	SIZE ADJ	1.005	ELEMENT	CD	DESCRIPTION	ADJ	S	BAT	T	DESCRIPTION	UNITS	YB	ADJ PRICE	RCN	TOTAL RCN	450,489		
NET AREA	2,168	DETAIL ADJ	1.000	FOUNDATION	3	FOUN. WALL	1.00	+	BAS	L	BASE AREA	1,216	1961	212.25	258,101	CONDITION ELEM CD			
\$NLA(RCN)	\$208	OVERALL	1.070	EXT COVER	1	WOOD SHINGLE	1.02	+	USF	L	UPPER STORY FIN	880	1961	121.55	106,964	EXTERIOR	G		
				ROOF SHAPE	1	GABLE	1.00	C	ENT	N	ENCLOSED ENTRY	24		128.95	3,095	INTERIOR	A		
				ROOF COVER	1	ASPH/COMP SHIN	1.00	+	OPA	N	OPEN PORCH	252		66.45	16,746	KITCHEN	G		
				FLOOR COVER	1	HARDWOOD	1.02	+	DKC	N	DECK-COMPOSITE	304		70.90	21,553	BATHS	A		
				INT. FINISH	2	DRYWALL	1.00	F	BAS	L	BASE AREA	16	2014	212.28	3,396	HEAT	U		
				HEATING/COOLING	9	WARM-COOL AIR	1.03	+	OVH	L	OVERHANG	56	1961	204.49	11,452	ELECT	U		
				FUEL SOURCE	2	GAS	1.00		F21	O	FPL 2S 1OP	1		9,946.40	9,946				
				USE	0		1.00		FIX	O	XTRA FIXTURES	8		2,404.60	19,237				
																	EFF.YR/AGE	2007 / 15	
																	COND	12 12 %	
																	FUNC	0	
																	ECON	0	
																	DEPR	12 % GD 88	
																	RCNLD	\$396,400	