

Key: 775

Town of Bourne - Fiscal Year 2024

12/18/2023 6:02 pm SEQ #: 775

LEG  
A  
L

CURRENT OWNER		PARCEL ID		LOCATION	
KENNEDY BONNIE L TRS SAGAMORE BEACH TRUST 515 HOLYOKE ST LUDLOW, MA 01056-1218		4.4-24-0		10 PHILLIPS RD	
TRANSFER HISTORY		DOS	T	SALE PRICE	BK-PG (Cert)
KENNEDY BONNIE L TRS		08/06/2021	U	730,000	34362-136
QUEENAN STEPHEN &		04/05/2019	A	558,000	31934-180
QUEENAN JAMES F JR ETUX		09/18/2015	F	100	29148-92

CLASS	CLASS%	DESCRIPTION			BN ID	BN	CARD
1010	100	SINGLE FAMILY				1	1 of 1
PMT NO	PMT DT	TY	DESC	AMOUNT	INSP	BY	1st %
03139	03/21/2003	2	ADDITIONS	15,200	06/14/2004	JS	100 100

L  
A  
N  
D

CD	T	AC/SF/UN	Nbhd	Infl1	N Index	ADJ BASE	SAF	Topo	Lpi	VC	CREDIT AMT	ADJ VALUE	
100	S	7,724 1	1.00	100	1.00	100	1.00	848,520	3.97	A	1.00	BVG 3.60	596,690

TOTAL	7,710 SF	ZONING	1	FRNT	70	ASSESSED	CURRENT	PREVIOUS
Nbhd	N SAG	NOTE	LAND	596,700	528,100			
Infl1	AVG		BUILDING	285,500	252,600			
N_Index	AVG		DETACHED	0	0			
			OTHER	0	0			
			<b>TOTAL</b>	<b>882,200</b>	<b>780,700</b>			

D  
E  
T  
A  
C  
H  
E  
D

TY	QUAL	COND	DIM/NOTE	YB	UNITS	ADJ PRICE	RCNLD
SHF	A	1.00 30	0.70 8X8			0.00	

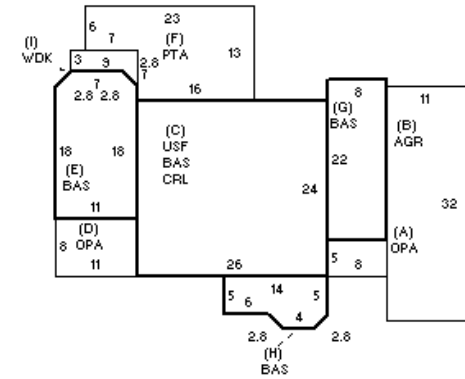

BUILDING	CD	ADJ	DESC	MEASURE	1/3/2022	NMP
MODEL	1		RESIDENTIAL	LIST	1/24/2018	EST
STYLE	7	1.00	CONVENTIONAL [100%]	REVIEW	8/3/2020	RP
QUALITY	A	1.00	AVERAGE [100%]			
FRAME	1	1.00	WOOD FRAME [100%]			

BLDG COMMENTS

B  
U  
I  
L  
D  
I  
N  
G

YEAR BLT	1926	SIZE ADJ	1.010	ELEMENT	CD	DESCRIPTION	ADJ	S	BAT	T	DESCRIPTION	UNITS	YB	ADJ PRICE	RCN	TOTAL RCN	366.006			
NET AREA	1,722	DETAIL ADJ	1.000	FOUNDATION	3	FOUN. WALL	1.00	+	OPA	N	OPEN PORCH	128		72.07	9,225	CONDITION ELEM	CD			
\$NLA(RCN)	\$213	OVERALL	1.040	EXT COVER	1	WOOD SHINGLE	1.02	B	AGR	N	ATT GARAGE	352		73.31	25,806	EXTERIOR	A			
				ROOF SHAPE	1	GABLE	1.00	C	CRL	N	BSMT CRAWL	624		26.98	16,838	INTERIOR	A			
				ROOF COVER	1	ASPH/COMP SHIN	1.00	C	USF	L	UPPER STORY FIN	624	1926	114.21	71,270	KITCHEN	G			
				FLOOR COVER	1	HARDWOOD	1.02	+	BAS	L	BASE AREA	1,098	1926	201.64	221,402	BATHS	A			
				INT. FINISH	1	PLASTER	1.00	F	PTA	N	PATIO	250		14.28	3,570	HEAT	A			
				HEATING/COOLING	1	FORCED AIR	1.00	I	WDK	N	WOOD DECK	29		66.57	1,931	ELECT	A			
				FUEL SOURCE	2	GAS	1.00	F21	O	FPL 2S 1OP	1		9,253.00	9,253						
				USE	0		1.00	FIX	O	XTRA FIXTURES	3		2,237.00	6,711						
																	EFF.YR/AGE	1997 / 25		
																	COND	22 22 %		
																	FUNC	0		
																	ECON	0		
																	DEPR	22	% GD	78
																	RCNLD	\$285,500		