

Key: 7877

Town of Bourne - Fiscal Year 2024

12/18/2023 6:02 pm SEQ #: 8.039

LEG
AL
L
AND

CURRENT OWNER				PARCEL ID				LOCATION			
GWIN THOMAS & NANCY BEARDALL 49 VICTORIA CIRCLE NEWTON CENTER, MA 02459				38.2-5-0				9 BENNETTS NECK DR			
TRANSFER HISTORY				DOS	T	SALE PRICE	BK-PG (Cert)				
GWIN THOMAS & KRICHER JOHN C & AUDETTE RONALD D &				05/09/2018	QS	355,000	(216122)				
				01/14/2000	QS	216,000	(156304)				
					XX		00779-00004				

CLASS	CLASS%	DESCRIPTION		BN ID	BN	CARD	
1010	100	SINGLE FAMILY			1	1 of 1	
PMT NO	PMT DT	TY	DESC	AMOUNT	INSP	BY	1st %
19161	03/12/2019	3	ALT/RENO	23,600	04/13/2021	TL	100 100
181120	12/28/2018	15	INSULATE/WEA	5,099			100 100
18575	07/11/2018	3	ALT/RENO	8,100			100 100
13688	10/07/2013	3	ALT/RENO	3,000	04/30/2018		100 100

L
AND

CD	T	AC/SF/UN	Nbhd	Infl1	N Index	ADJ BASE	SAF	Topo	Lpi	VC	CREDIT AMT	ADJ VALUE										
100	S	34,110	11	1.00	100	1.00	100	1.00			271,055	1.12	A	1.00	R07	1.15						238,230

D
E
T
A
C
H
E
D

TOTAL	34,020 SF	ZONING	1	FRNT	0	ASSESSED	CURRENT	PREVIOUS
Nbhd	POC	NOTE	LAND	238,200	201,700			
Infl1	AVG		BUILDING	313,700	277,600			
N_Index	AVG		DETACHED	0	0			
			OTHER	0	0			
			TOTAL	551,900	479,300			

TY	QUAL	COND	DIM/NOTE	YB	UNITS	ADJ PRICE	RCNLD	PHOTO	08/15/2001
									

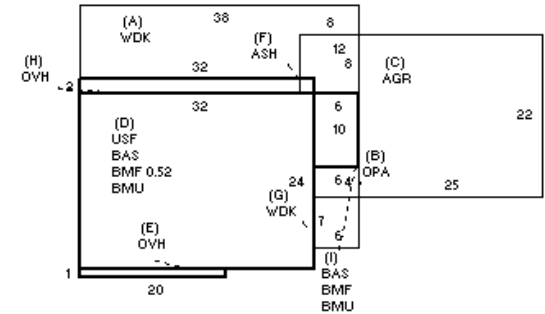

B
U
I
L
D
I
N
G

BUILDING	CD	ADJ	DESC	MEASURE	4/19/2018	TL
MODEL	1		RESIDENTIAL	LIST	4/19/2018	TL
STYLE	5	1.00	COLONIAL [100%]	REVIEW	8/12/2019	RP
QUALITY	A	1.00	AVERAGE [100%]			
FRAME	1	1.00	WOOD FRAME [100%]			

YEAR BLT	1973	SIZE ADJ	1.010	ELEMENT	CD	DESCRIPTION	ADJ	S	BAT	T	DESCRIPTION	UNITS	YB	ADJ PRICE	RCN	TOTAL RCN	407.370
NET AREA	1,680	DETAIL ADJ	1.000	FOUNDATION	4	FLR/WALL(FULL)	1.00	+	WDK	N	WOOD DECK	498		22.44	11,173		
\$NLA(RCN)	\$242	OVERALL	1.040	EXT COVER	1	WOOD SHINGLE	1.02	B	OPA	N	OPEN PORCH	24		99.88	2,397		
				ROOF SHAPE	1	GABLE	1.00	C	AGR	N	ATT GARAGE	550		64.92	35,706		
				ROOF COVER	1	ASPH/COMP SHIN	1.00	+	BMU	N	BSMT UNFINISHED	828		38.30	31,715		
				FLOOR COVER	3	W/W CARPET	1.00	D	BMF	N	BSMT FINISH	399		61.38	24,489		
				INT. FINISH	2	DRYWALL	1.00	+	BAS	L	BASE AREA	828	1973	208.30	172,472		
				HEATING/COOLING	2	HOT WATER	1.02	D	USF	L	UPPER STORY FIN	768	1973	114.21	87,716		
				FUEL SOURCE	2	GAS	1.00	+	OVH	L	OVERHANG	84	1973	190.22	15,979		
				USE	0		1.00	F	ASH	N	ATT SHED	64		25.06	1,604		
								I	BMF	N	BSMT FINISH	60		61.38	3,683		
									F21	O	FPL 2S 1OP	1		9,253.00	9,253		
									FIX	O	XTRA FIXTURES	5		2,236.94	11,185		

CONDITION ELEM	CD
EXTERIOR	A
INTERIOR	A
KITCHEN	A
BATHS	A
HEAT	A
ELECT	A

EFF.YR/AGE	1996 / 26
COND	23 23 %
FUNC	0
ECON	0
DEPR	23 % GD 77

RCNLD	\$313,700
-------	-----------