

Key: 7967

Town of Bourne - Fiscal Year 2024

12/18/2023 6:02 pm SEQ #: 8.129

LEGAL

Table with columns: CURRENT OWNER, PARCEL ID, LOCATION, TRANSFER HISTORY, DOS, T, SALE PRICE, BK-PG (Cert)

Table with columns: CLASS, CLASS%, DESCRIPTION, BN ID, BN, CARD, PMT NO, PMT DT, TY, DESC, AMOUNT, INSP, BY, 1st, %

LAND

Table with columns: CD, T, AC/SF/UN, Nbhd, Infl1, N Index, ADJ BASE, SAF, Topo, Lpi, VC, CREDIT AMT, ADJ VALUE

Table with columns: TOTAL, ZONING, FRNT, ASSESSED, CURRENT, PREVIOUS, Nbhd, POC, N O T E, LAND, BUILDING, DETACHED, OTHER, TOTAL

DETACHED

Table with columns: TY, QUAL, COND, DIM/NOTE, YB, UNITS, ADJ PRICE, RCNLD

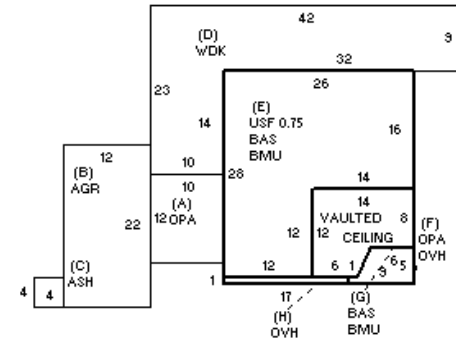

BUILDING

Table with columns: BUILDING, CD, ADJ, DESC, MEASURE, 8/17/2023, SL

Table with column: BLDG COMMENTS

UNIT

Table with columns: YEAR BLT, SIZE ADJ, NET AREA, SNLA(RCN), CAPACITY, UNITS, ADJ

Table with columns: ELEMENT, CD, DESCRIPTION, ADJ

Table with columns: S, BAT, T, DESCRIPTION, UNITS, YB, ADJ PRICE, RCN

Table with columns: TOTAL RCN, CONDITION ELEM, CD, EFF.YR/AGE, COND, FUNC, ECON, DEPR, RCNLD