

Key: 81

Town of Bourne - Fiscal Year 2024

12/18/2023 6:02 pm SEQ #: 79

LEGALS LAND

Table with columns: CURRENT OWNER, PARCEL ID, LOCATION, TRANSFER HISTORY, DOS, T, SALE PRICE, BK-PG (Cert), CD, T, AC/SF/UN, Nbhd, Infl1, N Index, ADJ BASE, SAF, Topo, Lpi, VC, CREDIT AMT, ADJ VALUE

Table with columns: CLASS, CLASS%, DESCRIPTION, BN ID, BN, CARD, PMT NO, PMT DT, TY, DESC, AMOUNT, INSP, BY, 1st, %

Table with columns: TOTAL, 2.610 Acres, ZONING, 1, FRNT, 197, ASSESSED, CURRENT, PREVIOUS, Nbhd, N SAG, Infl1, AVG, N_Index, AVG

Table with columns: TY, QUAL, COND, DIM/NOTE, YB, UNITS, ADJ PRICE, RCNLD

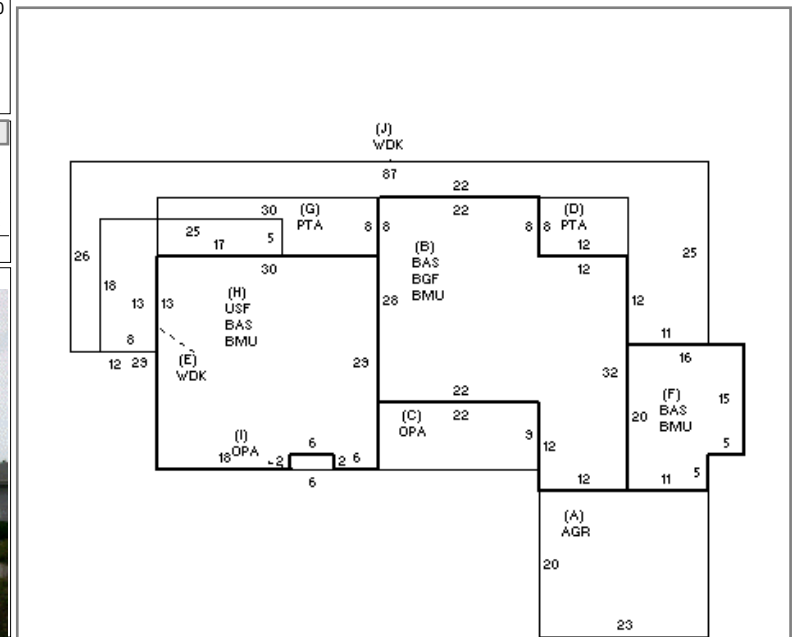

Table with columns: BUILDING, CD, ADJ, DESC, MEASURE, 7/14/2021, NMP, MODEL, STYLE, QUALITY, FRAME

BLDG COMMENTS

DETACHED

BUILDING

Table with columns: YEAR BLT, SIZE ADJ, 0.995, NET AREA, 3,011, \$NLA(RCN), \$352, OVERALL, 1.190, ELEMENT, CD, DESCRIPTION, ADJ, S, BAT, T, DESCRIPTION, UNITS, YB, ADJ PRICE, RCN, TOTAL RCN, 1,059,328, CONDITION ELEM, CD, EFF.YR/AGE, 2010 / 12, COND, 9 9 %, FUNC, 0, ECON, 0, DEPR, 9 % GD, 91, RCNLD, \$964,000