

Key: 8104

Town of Bourne - Fiscal Year 2024

12/18/2023 6:02 pm SEQ #: 8.270

LEGAL

Table with columns: CURRENT OWNER, PARCEL ID, LOCATION, TRANSFER HISTORY, DOS, T, SALE PRICE, BK-PG (Cert)

Table with columns: CLASS, CLASS%, DESCRIPTION, BN ID, BN, CARD, PMT NO, PMT DT, TY, DESC, AMOUNT, INSP, BY, 1st, %

LAND

Table with columns: CD, T, AC/SF/UN, Nbhd, Infl1, N Index, ADJ BASE, SAF, Topo, Lpi, VC, CREDIT AMT, ADJ VALUE

Table with columns: TOTAL, 10,019 SF, ZONING, 1, FRNT, 0, ASSESSED, CURRENT, PREVIOUS

DETACHED

Table with columns: TY, QUAL, COND, DIM/NOTE, YB, UNITS, ADJ PRICE, RCNLD

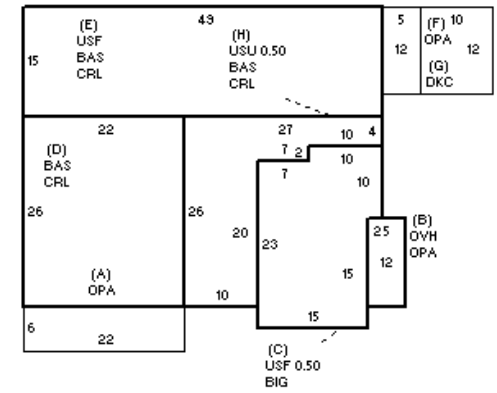

BUILDING

Table with columns: BUILDING, CD, ADJ, DESC, MEASURE, 9/13/2023, SL

Table with column: BLDG COMMENTS

UNIT

Table with columns: YEAR BLT, 2008, SIZE ADJ, 1.000, NET AREA, 2,635, DETAIL ADJ, 1.000, \$NLA(RCN), \$260, OVERALL, 1.190

Table with columns: ELEMENT, CD, DESCRIPTION, ADJ

Table with columns: S, BAT, T, DESCRIPTION, UNITS, YB, ADJ PRICE, RCN

Table with columns: TOTAL RCN, 684,768, CONDITION ELEM, CD, EFF.YR/AGE, 2009 / 13, COND, 10 10 %, FUNC, 0, ECON, 0, DEPR, 10 % GD, 90, RCNLD, \$616,300