

Key: 8260

Town of Bourne - Fiscal Year 2024

12/18/2023 6:02 pm SEQ #: 8.419

LEGAL

CURRENT OWNER				PARCEL ID				LOCATION			
LESSA DANIEL J & PENNY J LESSA PO BOX 614 POCASSET, MA 02559				38.3-290-0				10 WEETAMOE RD			
				TRANSFER HISTORY				DOS	T	SALE PRICE	BK-PG (Cert)
				LESSA DANIEL J & PARNAGIAN SIMPAT C &				05/07/1999	QS	190,000	12253-269
				05/11/1995	XX		9663-246				

CLASS	CLASS%	DESCRIPTION			BN ID	BN	CARD	
1010	100	SINGLE FAMILY				1	1 of 1	
PMT NO	PMT DT	TY	DESC	AMOUNT	INSP	BY	1st	%
12462	07/09/2012	8	POOL	37,000	08/16/2013	DB	100	100
12455	07/05/2012	3	ALT/RENO	6,500	08/16/2013	DB	100	100
10670	11/09/2010	3	ALT/RENO	20,000	08/16/2013	DB	100	100
10625	10/18/2010	2	ADDITIONS	12,500	01/07/2016	SW	100	100
06513	08/16/2006	3	ALT/RENO	5,000	08/23/2007	DB	100	100

LAND

CD	T	AC/SF/UN	Nbhd	Infl1	N Index	ADJ BASE	SAF	Topo	Lpi	VC	CREDIT AMT	ADJ VALUE					
100	S	17,900	11	1.00	100	1.00	100	1.00	589,250	1.88	A	1.00	BA+	2.50			454,280

TOTAL	17,903 SF	ZONING	1	FRNT	0	ASSESSED	CURRENT	PREVIOUS
Nbhd	POC	NOTE	LAND	454,300	353,800			
Infl1	AVG		BUILDING	440,900	390,100			
N_Index	AVG		DETACHED	73,300	69,700			
			OTHER	0	0			
			TOTAL	968,500	813,600			

DETAILED

TY	QUAL	COND	DIM/NOTE	YB	UNITS	ADJ PRICE	RCNLD	
DGF	S	3.00	10 0.90	16 X 20	2012	320	121.80	35,100
IPG	S	3.00	10 0.90	12 X 24	2012	288	128.76	33,400
HTB	E	1.90	10 0.90			1	5,369.97	4,800

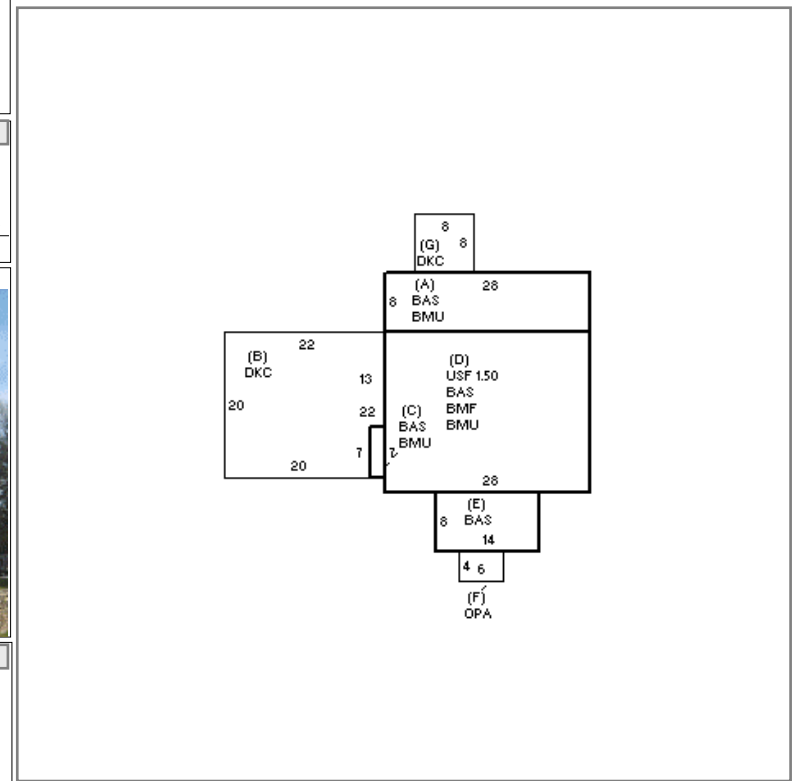

BUILDING

BUILDING	CD	ADJ	DESC	MEASURE	5/5/2001	TL
MODEL	1		RESIDENTIAL	LIST	5/5/2001	TL
STYLE	7	1.00	CONVENTIONAL [100%]	REVIEW	9/24/2021	RP
QUALITY	+	1.05	AVERAGE + [100%]			
FRAME	1	1.00	WOOD FRAME [100%]			

BLDG COMMENTS

INDING

YEAR BLT	1930	SIZE ADJ	1.010	ELEMENT	CD	DESCRIPTION	ADJ	S	BAT	T	DESCRIPTION	UNITS	YB	ADJ PRICE	RCN	TOTAL RCN	479,272		
NET AREA	1,890	DETAIL ADJ	1.000	FOUNDATION	4	FLR/WALL(FULL)	1.00	+	BMU	N	BSMT UNFINISHED	854		41.38	35,337	CONDITION ELEM	CD		
\$NLA(RCN)	\$254	OVERALL	1.070	EXT COVER	1	WOOD SHINGLE	1.02	+	DKC	N	DECK-COMPOSITE	490		71.25	34,912	EXTERIOR	G		
				ROOF SHAPE	1	GABLE	1.00	D	BMF	N	BSMT FINISH	616		49.72	30,627	INTERIOR	G		
				ROOF COVER	1	ASPH/COMP SHIN	1.00	D	USF	L	UPPER STORY FIN	924	1930	122.15	112,871	KITCHEN	G		
				FLOOR COVER	1	HARDWOOD	1.02	+	BAS	L	BASE AREA	966	1930	225.02	217,372	BATHS	G		
				INT. FINISH	2	DRYWALL	1.00	F	OPA	N	OPEN PORCH	24		107.90	2,590	HEAT	U		
				HEATING/COOLING	9	WARM-COOL AIR	1.03		BMU	N	BSMT UNFINISHED	248		69.66	17,275	ELECT	U		
				FUEL SOURCE	2	GAS	1.00		F31	O	FPL 3S 1OP	1		11,373.40	11,373				
				USE	0		1.00		FIX	O	XTRA FIXTURES	7		2,416.50	16,916				
																		EFF.YR/AGE	2011 / 11
																		COND	8 8 %
																		FUNC	0
																		ECON	0
																		DEPR	8 % GD 92
																		RCNLD	\$440,900