

Key: 8306

Town of Bourne - Fiscal Year 2024

12/18/2023 6:02 pm SEQ #: 8.464

LEGAL

LAND

DETACHED

BUILDING

| CURRENT OWNER | | | | PARCEL ID | | | | LOCATION | | | |
|---|--|--|--|------------|----|------------|--------------|---------------|--|--|--|
| YOUNIS THOMAS J & LINDA A TRS OF YOUNIS REALTY TR 575 WASHINGTON ST BROOKLINE, MA 02446-4510 | | | | 38.3-343-0 | | | | 9 WABENAKI RD | | | |
| TRANSFER HISTORY | | | | DOS | T | SALE PRICE | BK-PG (Cert) | | | | |
| YOUNIS THOMAS J & LINDA A | | | | 11/09/2020 | F | 7,500 | 33452-314 | | | | |
| YOUNIS THOMAS J & LINDA A | | | | 02/05/2002 | F | 1 | 14787-203 | | | | |
| YOUNIS THOMAS J & | | | | | XX | | 04716-00300 | | | | |

| CLASS | CLASS% | DESCRIPTION | | BN ID | BN | CARD | |
|------------|------------|---------------|--------------|--------|------------|--------|---------|
| 1010 | 100 | SINGLE FAMILY | | | 1 | 1 of 1 | |
| PMT NO | PMT DT | TY | DESC | AMOUNT | INSP | BY | 1st % |
| EXB-21-731 | 10/08/2021 | 3 | ALT/RENO | | 11/02/2022 | SL | 100 100 |
| 16229 | 04/04/2016 | 15 | INSULATE/WEA | 4,000 | 11/02/2022 | SL | 100 100 |
| 07551 | 09/10/2007 | 9 | DECK | 15,000 | 09/18/2008 | DB | 100 100 |
| 07266 | 08/21/2007 | 3 | ALT/RENO | 4,500 | 06/20/2007 | TL | 100 100 |

| | | | | | | | | |
|---------|-----------|---|----------|---------|---------|----------|---------|----------|
| TOTAL | 17,975 SF | ZONING | 1 | FRNT | 0 | ASSESSED | CURRENT | PREVIOUS |
| Nbhd | POC | NOTE PER PL 687 PG 79 -PART OF 3 WABENAKI WAS DELETED INTO THIS PARCEL (3400) SQFT | LAND | 290,900 | 257,500 | | | |
| Infl1 | AVG | | BUILDING | 292,000 | 249,900 | | | |
| N_Index | AVG | | DETACHED | 0 | 0 | | | |
| | | | OTHER | 0 | 0 | | | |
| | | TOTAL | | 582,900 | 507,400 | | | |

| TY | QUAL | COND | DIM/NOTE | YB | UNITS | ADJ PRICE | RCNLD |
|----|------|------|----------|----|-------|-----------|-------|
| | | | | | | | |

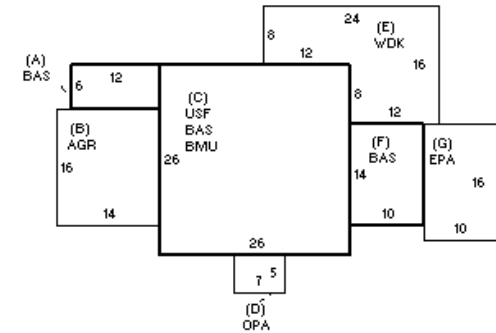

| BUILDING | CD | ADJ | DESC | MEASURE | 11/2/2022 | SL |
|----------|----|------|-------------------|---------|-----------|-----|
| MODEL | 1 | | RESIDENTIAL | LIST | 11/2/2022 | EST |
| STYLE | 4 | 1.05 | CAPE [100%] | REVIEW | 11/2/2022 | SL |
| QUALITY | A | 1.00 | AVERAGE [100%] | | | |
| FRAME | 1 | 1.00 | WOOD FRAME [100%] | | | |

| YEAR BLT | 1927 <th>SIZE ADJ</th> <td>1.010 <th>ELEMENT</th> <th>CD</th> <th>DESCRIPTION</th> <th>ADJ</th> <th>S</th> <th>BAT</th> <th>T</th> <th>DESCRIPTION</th> <th>UNITS</th> <th>YB</th> <th>ADJ PRICE</th> <th>RCN</th> </td> | SIZE ADJ | 1.010 <th>ELEMENT</th> <th>CD</th> <th>DESCRIPTION</th> <th>ADJ</th> <th>S</th> <th>BAT</th> <th>T</th> <th>DESCRIPTION</th> <th>UNITS</th> <th>YB</th> <th>ADJ PRICE</th> <th>RCN</th> | ELEMENT | CD | DESCRIPTION | ADJ | S | BAT | T | DESCRIPTION | UNITS | YB | ADJ PRICE | RCN |
|------------|--|------------|---|-----------------|----|-----------------|------|---|-----|---|-----------------|-------|------|-----------|---------|
| NET AREA | 1,564 | DETAIL ADJ | 1.000 | FOUNDATION | 4 | FLR/WALL(FULL) | 1.00 | + | BAS | L | BASE AREA | 888 | 1927 | 228.33 | 202,755 |
| \$NLA(RCN) | \$246 | OVERALL | 1.140 | EXT COVER | 1 | WOOD SHINGLE | 1.02 | B | AGR | N | ATT GARAGE | 224 | | 80.36 | 18,001 |
| | | | | ROOF SHAPE | 1 | GABLE | 1.00 | C | BMU | N | BSMT UNFINISHED | 676 | | 53.00 | 35,828 |
| | | | | ROOF COVER | 1 | ASPH/COMP SHIN | 1.00 | C | USF | L | UPPER STORY FIN | 676 | 1927 | 125.20 | 84,633 |
| | | | | FLOOR COVER | 1 | HARDWOOD | 1.02 | D | OPA | N | OPEN PORCH | 35 | | 93.82 | 3,284 |
| | | | | INT. FINISH | 2 | DRYWALL | 1.00 | E | WDK | N | WOOD DECK | 288 | | 29.82 | 8,588 |
| | | | | HEATING/COOLING | 11 | HT WATER CL AIR | 1.05 | G | EPA | N | ENCLOSED PORCH | 160 | | 84.97 | 13,595 |
| | | | | FUEL SOURCE | 2 | GAS | 1.00 | | F21 | O | FPL 2S 1OP | 1 | | 10,142.70 | 10,143 |
| | | | | USE | 0 | | 1.00 | | FIX | O | XTRA FIXTURES | 3 | | 2,452.10 | 7,356 |

| TOTAL RCN | 384,182 | |
|----------------|-----------|---------|
| CONDITION ELEM | CD | |
| EXTERIOR | A | |
| INTERIOR | A | |
| KITCHEN | A | |
| BATHS | A | |
| HEAT | A | |
| ELECT | A | |
| EFF.YR/AGE | 1995 / 27 | |
| COND | 24 | 24 % |
| FUNC | 0 | |
| ECON | 0 | |
| DEPR | 24 | % GD 76 |
| RCNLD | \$292,000 | |