

Key: 8320

Town of Bourne - Fiscal Year 2024

12/18/2023 6:02 pm SEQ #: 8.477

LEGAL

CURRENT OWNER		PARCEL ID		LOCATION	
MCAWARD KIM E ETUX JOHN M MCAWARD 97 JARVIS CIRCLE NEEDHAM, MA 02492		38.3-358-0		800 SHORE RD	
TRANSFER HISTORY		DOS	T	SALE PRICE	BK-PG (Cert)
MCAWARD KIM E ETUX		02/18/2011	QS	315,000	25268-225
MOLLOY NANCY		02/18/2011	N		25268-220-3
NORTON JANET ELAINE		11/11/2004	F		NA-NA

CLASS	CLASS%	DESCRIPTION		BN ID	BN	CARD		
1010	100	SINGLE FAMILY			1	1 of 1		
PMT NO	PMT DT	TY	DESC	AMOUNT	INSP	BY	1st	%
08651	11/21/2008	3	ALT/RENO	7,590	06/17/2009		100	100
200657	10/13/2000	4	DETACH.STRUC	800	06/05/2001	TL	100	100

LAND

CD	T	AC/SF/UN	Nbhd	Infl1	N Index	ADJ BASE	SAF	Topo	Lpi	VC	CREDIT AMT	ADJ VALUE					
100	S	14,508	11	1.00	100	1.00	1.00	1.00	377,120	2.25	A	1.00	BAV	1.60			282,230

DETACHED

TOTAL	14,508 SF	ZONING	1	FRNT	0	ASSESSED	CURRENT	PREVIOUS
Nbhd	POC	NOTE	LAND	282,200	249,800			
Infl1	AVG		BUILDING	251,200	222,300			
N_Index	AVG		DETACHED	0	0			
			OTHER	0	0			
<b>TOTAL</b>				<b>533,400</b>	<b>472,100</b>			

BUILDING

TY	QUAL	COND	DIM/NOTE	YB	UNITS	ADJ PRICE	RCNLD	PHOTO	06/20/2011
SHF	A	1.00	10 0.90 8 X 10			0.00			

BLDG COMMENTS

BUILDING	CD	ADJ	DESC	MEASURE	6/9/2011	TL
MODEL	1		RESIDENTIAL	LIST	6/9/2011	TL
STYLE	1	0.95	RANCH [100%]	REVIEW	6/9/2011	TL
QUALITY	A	1.00	AVERAGE [100%]			
FRAME	1	1.00	WOOD FRAME [100%]			

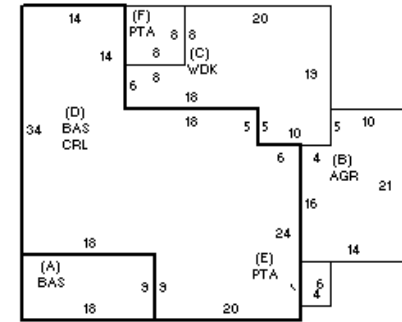

YEAR BLT	1940	SIZE ADJ	1.015	ELEMENT	CD	DESCRIPTION	ADJ	S	BAT	T	DESCRIPTION	UNITS	YB	ADJ PRICE	RCN	TOTAL RCN	330,540
NET AREA	1,268	DETAIL ADJ	1.000	FOUNDATION	3	FOUN. WALL	1.00	+	BAS	L	BASE AREA	1,268	1940	196.53	249,195		
\$NLA(RCN)	\$261	OVERALL	1.030	EXT COVER	1	WOOD SHINGLE	1.02	B	AGR	N	ATT GARAGE	274		72.97	19,993		
				ROOF SHAPE	1	GABLE	1.00	C	WDK	N	WOOD DECK	378		22.33	8,441		
				ROOF COVER	2	WOOD SHINGLES	1.02	D	CRL	N	BSMT CRAWL	1,106		21.27	23,530		
				FLOOR COVER	1	HARDWOOD	1.02	+	PTA	N	PATIO	88		15.22	1,339		
				INT. FINISH	2	DRYWALL	1.00		ATF	N	ATTIC FINISH	200		64.90	12,980		
				HEATING/COOLING	2	HOT WATER	1.02		F11	O	FPL 1S 1OP	1		8,382.40	8,382		
				FUEL SOURCE	2	GAS	1.00		FIX	O	XTRA FIXTURES	3		2,226.47	6,679		
				USE	0		1.00										

CONDITION ELEM	CD	TOTAL RCN
EXTERIOR	A	
INTERIOR	A	
KITCHEN	A	
BATHS	A	
HEAT	A	
ELECT	A	

EFF. YR/AGE	1995 / 27
COND	24 24 %
FUNC	0
ECON	0
DEPR	24 % GD 76

RCNLD	\$251,200
-------	-----------