

Key: 8409

Town of Bourne - Fiscal Year 2024

12/18/2023 6:02 pm SEQ #: 8.572

LEGALS

CURRENT OWNER				PARCEL ID				LOCATION			
BARTON JACOB J E ETUX DOREEN G BARTON 11 OBSERVATORY LANE POCASSET, MA 02559-1536				39.0-19-0				11 OBSERVATORY LN			
TRANSFER HISTORY				DOS	T	SALE PRICE	BK-PG (Cert)				
BARTON JACOB J E ETUX				08/22/2008	A	250,000	23114-316				
FAUX ROBERT L &				03/30/1999	X		12160-97				
FAUX JOYCE E				03/30/1999	X		12160-86				

CLASS	CLASS%	DESCRIPTION			BN ID	BN	CARD	
1010	100	SINGLE FAMILY				1	1 of 1	
PMT NO	PMT DT	TY	DESC	AMOUNT	INSP	BY	1st	%
EXB-23-322	05/25/2023	14	SOLAR	45,000			100	100
B-20-277	09/21/2020	2	ADDITIONS	35,000	06/24/2021	RP	100	100
200653	10/13/2000	3	ALT/RENO	7,400	04/25/2001	TL	100	100

LAND

CD	T	AC/SF/UN	Nbhd	Infl1	N Index	ADJ BASE	SAF	Topo	Lpi	VC	CREDIT AMT	ADJ VALUE					
100	S	10,280	11	1.00	100	1.00	100	1.00	235,700	3.05	A	1.00	R05	1.00			169,750

TOTAL	10,280 SF	ZONING	1	FRNT	0	ASSESSED	CURRENT	PREVIOUS
Nbhd	POC	N O T E  on Shop Pond	LAND	169,800	150,200			
Infl1	AVG		BUILDING	255,000	225,700			
N_Index	AVG		DETACHED	2,100	2,000			
			OTHER	0	0			
			<b>TOTAL</b>	<b>426,900</b>	<b>377,900</b>			

DETACHED

TY	QUAL	COND	DIM/NOTE	YB	UNITS	ADJ PRICE	RCNLD	
SHF	A	1.00	10 0.90	12 X 12		144	16.42	2,100

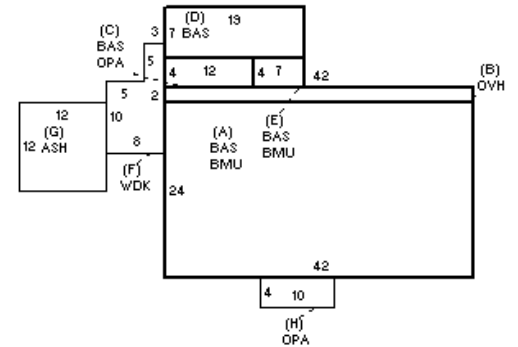

BUILDING	CD	ADJ	DESC	MEASURE	6/24/2021	RP
MODEL	1		RESIDENTIAL	LIST	6/24/2021	RP
STYLE	1	0.95	RANCH [100%]	REVIEW	6/24/2021	TL
QUALITY	A	1.00	AVERAGE [100%]			
FRAME	1	1.00	WOOD FRAME [100%]			

BLDG COMMENTS

BUILDING

YEAR BLT	1973	SIZE ADJ	1.015	ELEMENT	CD	DESCRIPTION	ADJ	S	BAT	T	DESCRIPTION	UNITS	YB	ADJ PRICE	RCN	TOTAL RCN	307,237
NET AREA	1,301	DETAIL ADJ	1.000	FOUNDATION	4	FLR/WALL(FULL)	1.00	+	BMU	N	BSMT UNFINISHED	1,036		36.64	37,961		
\$NLA(RCN)	\$236	OVERALL	0.990	EXT COVER	1	WOOD SHINGLE	1.02	A	BAS	L	BASE AREA	1,008	1973	188.89	190,405		
				ROOF SHAPE	1	GABLE	1.00	B	OVH	L	OVERHANG	84	1973	181.97	15,286		
				ROOF COVER	1	ASPH/COMP SHIN	1.00	+	OPA	N	OPEN PORCH	88		72.21	6,355		
				FLOOR COVER	1	HARDWOOD	1.02	+	BAS	L	BASE AREA	209	2020	188.89	39,479		
				INT. FINISH	2	DRYWALL	1.00	F	WDK	N	WOOD DECK	95		44.21	4,200		
				HEATING/COOLING	1	FORCED AIR	1.00	G	ASH	N	ATT SHED	144		23.29	3,354		
				FUEL SOURCE	2	GAS	1.00	F11	O	FPL 1S 1OP	1		8,056.90	8,057			
				USE	0		1.00	FIX	O	XTRA FIXTURES	1		2,140.30	2,140			
																CONDITION ELEM	CD
																EXTERIOR	A
																INTERIOR	A
																KITCHEN	G
																BATHS	A
																HEAT	A
																ELECT	A
																EFF.YR/AGE	2002 / 20
																COND	17 17 %
																FUNC	0
																ECON	0
																DEPR	17 % GD 83
																RCNLD	\$255,000