

Key: 852

Town of Bourne - Fiscal Year 2024

12/18/2023 6:02 pm SEQ #: 850

LEGALS

Table with columns: CURRENT OWNER, PARCEL ID, LOCATION, TRANSFER HISTORY, DOS, T, SALE PRICE, BK-PG (Cert). Includes owner names and parcel details.

Table with columns: CLASS, CLASS%, DESCRIPTION, BN ID, BN, CARD. Includes payment history and transaction details.

LAND

Table with columns: CD, T, AC/SF/UN, Nbhd, Infil1, N Index, ADJ BASE, SAF, Topo, Lpi, VC, CREDIT AMT, ADJ VALUE. Includes zoning and assessed value information.

DETACHED

Table with columns: TY, QUAL, COND, DIM/NOTE, YB, UNITS, ADJ PRICE, RCNLD. Includes building quality and condition data.

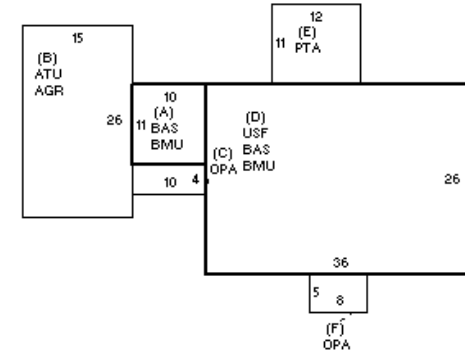

BUILDING

Table with columns: BUILDING, CD, ADJ, DESC, MEASURE, 1/21/2022, NMP. Includes building model and quality metrics.

Table with columns: BLDG COMMENTS. Includes a section for building remarks.

INDING

Table with columns: YEAR BLT, SIZE ADJ, NET AREA, \$NLA(RCN), CAPACITY, UNITS, ADJ. Includes building age and capacity information.

Table with columns: ELEMENT, CD, DESCRIPTION, ADJ. Lists building components like foundation, roof, and floors.

Table with columns: S, BAT, T, DESCRIPTION, UNITS, YB, ADJ PRICE, RCN. Lists building systems like basements, attics, and porches.

Table with columns: TOTAL RCN, CONDITION ELEM, CD, EFF.YR/AGE, COND, FUNC, ECON, DEPR, RCNLD. Includes total value and condition summary.