

Key: 8728

Town of Bourne - Fiscal Year 2024

12/18/2023 6:02 pm SEQ #: 8.901

LEGAL

CURRENT OWNER				PARCEL ID				LOCATION			
TIMMINS MICHAEL J & KATHLEEN M TIMMINS 40 SPINNAKER LN POCASSET, MA 02559-1912				39.0-251-0				40 SPINNAKER LN			
TRANSFER HISTORY				DOS	T	SALE PRICE	BK-PG (Cert)				
TIMMINS MICHAEL J & PRIESTLY DONALD H TR				02/07/1997	QS	150,700	10602-139				
RAFS LIMITED PARTNERSHIP				06/29/1994	B	850,000	N/A-N/A				
				03/20/1994	B	100	N/A-N/A				

CLASS	CLASS%	DESCRIPTION			BN ID	BN	CARD	
1010	100	SINGLE FAMILY				1	1 of 1	
PMT NO	PMT DT	TY	DESC	AMOUNT	INSP	BY	1st	%
12764	10/19/2012	9	DECK	10,000	08/16/2013	DB	100	100
12765	10/19/2012	9	DECK	2,800	08/16/2013	DB	100	100
990489	08/05/1999	3	ALT/RENO	2,500	10/03/2000	TL	100	100
980331	06/22/1998	4	DETACH.STRUC		02/16/1999	JS	100	100
980236	05/15/1998	2	ADDITIONS	6,500	02/16/1999	JS	100	100

LAND

CD	T	AC/SF/UN	Nbhd	Infl1	N Index	ADJ BASE	SAF	Topo	Lpi	VC	CREDIT AMT	ADJ VALUE									
100	S	17,638	11	1.00	100	1.00	100	1.00			235,700	1.90	A	1.00	R05	1.00					181,300

DETACHED

TOTAL	17,642 SF	ZONING	1	FRNT	0	ASSESSED	CURRENT	PREVIOUS
Nbhd	POC	NOTE	LAND	181,300	160,500			
Infl1	AVG		BUILDING	323,400	289,800			
N_Index	AVG		DETACHED	0	0			
			OTHER	0	0			
			<b>TOTAL</b>	<b>504,700</b>	<b>450,300</b>			

BUILDING

TY	QUAL	COND	DIM/NOTE	YB	UNITS	ADJ PRICE	RCNLD	PHOTO	07/14/2010
SHF	A	1.00	10 0.90 8 X 12			0.00			
SHF	A	1.00	10 0.90 8 X 12			0.00			

BUILDING	CD	ADJ	DESC	MEASURE	7/14/2010	TL
MODEL	1		RESIDENTIAL	LIST	7/14/2010	TL
STYLE	5	1.00	COLONIAL [100%]	REVIEW	7/14/2010	TL
QUALITY	A	1.00	AVERAGE [100%]			
FRAME	1	1.00	WOOD FRAME [100%]			

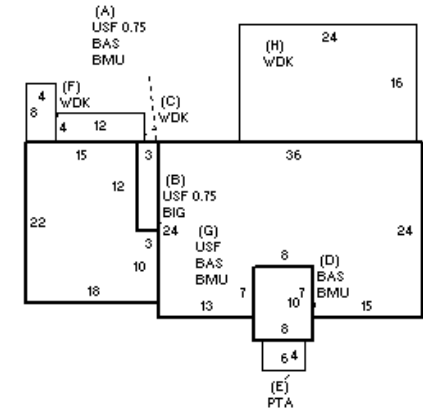

BLDG COMMENTS

G

YEAR BLT	1996	SIZE ADJ	1.005	ELEMENT	CD	DESCRIPTION	ADJ	S	BAT	T	DESCRIPTION	UNITS	YB	ADJ PRICE	RCN	TOTAL RCN	404,264
NET AREA	2,029	DETAIL ADJ	1.000	FOUNDATION	4	FLR/WALL(FULL)	1.00	+	BMU	N	BSMT UNFINISHED	924		38.11	35,217		
\$NLA(RCN)	\$199	OVERALL	1.040	EXT COVER	1	WOOD SHINGLE	1.02	+	BAS	L	BASE AREA	924	1996	207.27	191,515		
				ROOF SHAPE	1	GABLE	1.00	+	USF	L	UPPER STORY FIN	1,105	1996	108.67	120,078		
				ROOF COVER	1	ASPH/COMP SHIN	1.00	B	BIG	N	BUILT-IN GARAGE	360		92.54	33,316		
				FLOOR COVER	13	HARDWOOD-W/W	1.00	+	WDK	N	WOOD DECK	464		22.33	10,359		
				INT. FINISH	2	DRYWALL	1.00	E	PTA	N	PATIO	24		17.64	423		
				HEATING/COOLING	2	HOT WATER	1.02		FIX	O	XTRA FIXTURES	6		2,225.93	13,356		
				FUEL SOURCE	2	GAS	1.00										
				USE	0		1.00										
																EFF.YR/AGE	1999 / 23
																COND	20 20 %
																FUNC	0
																ECON	0
																DEPR	20 % GD 80
																RCNLD	\$323,400