

Key: 8791

Town of Bourne - Fiscal Year 2024

12/18/2023 6:02 pm SEQ #: 8.971

LEGAL

LAND

CURRENT OWNER				PARCEL ID				LOCATION				
NEELON PAUL R & KATHERINE E TRS GILDER REALTY TRUST PO BOX 623 POCASSET, MA 02559				42.0-35-0				84 OLD NORTH RD				
TRANSFER HISTORY				DOS	T	SALE PRICE	BK-PG (Certs)					
NEELON PAUL R & KATHERINE				04/05/2004	F	1	18406-279					
NEELON PAUL R ETUX				11/05/2003	QS	2,100,000	17891-95					
BOLINDER IDA CHRISTINE				06/03/1998	O	385,000	11474-307					
CD	T	AC/SF/UN	Nbhd	Infl1	N Index	ADJ BASE	SAF	Topo	Lpi	VC	CREDIT AMT	ADJ VALUE
100	S	40,000	11	1.00	100	1,414,200	1.00	A	1.00	BSP	6.00	1,298,360
300	A	1,782	11	1.00	100	97,800	1.00	A	1.00	BSP	6.00	174,280

CLASS	CLASS%	DESCRIPTION			BN ID	BN	CARD	
1010	100	SINGLE FAMILY				1	1 of 1	
PMT NO	PMT DT	TY	DESC	AMOUNT	INSP	BY	1st	%
930556	10/21/1993	1	NEW CONSTRUC	250,000	04/23/1995	JS	0	100

TOTAL	2.700 Acres	ZONING	1	FRNT	0	ASSESSED	CURRENT	PREVIOUS
Nbhd	POC	N O T E	ABUTS WINCOVE ASSOCIATION BEACH=WFE MAILING ADDRESS CHG PER TP 1/31/2011			LAND	1,472,600	1,303,000
Infl1	AVG		BUILDING	991,800	877,700			
N_Index	AVG		DETACHED	0	0			
			OTHER	0	0			
			TOTAL	2,464,400	2,180,700			

TY	QUAL	COND	DIM/NOTE	YB	UNITS	ADJ PRICE	RCNLD



BUILDING	CD	ADJ	DESC	MEASURE	7/24/2001	EB
MODEL	1		RESIDENTIAL	LIST	7/24/2001	EB
STYLE	8	1.10	CONTEMPORARY [100%]	REVIEW	7/24/2001	EB
QUALITY	V	1.35	VERY GOOD [100%]			
FRAME	1	1.00	WOOD FRAME [100%]			

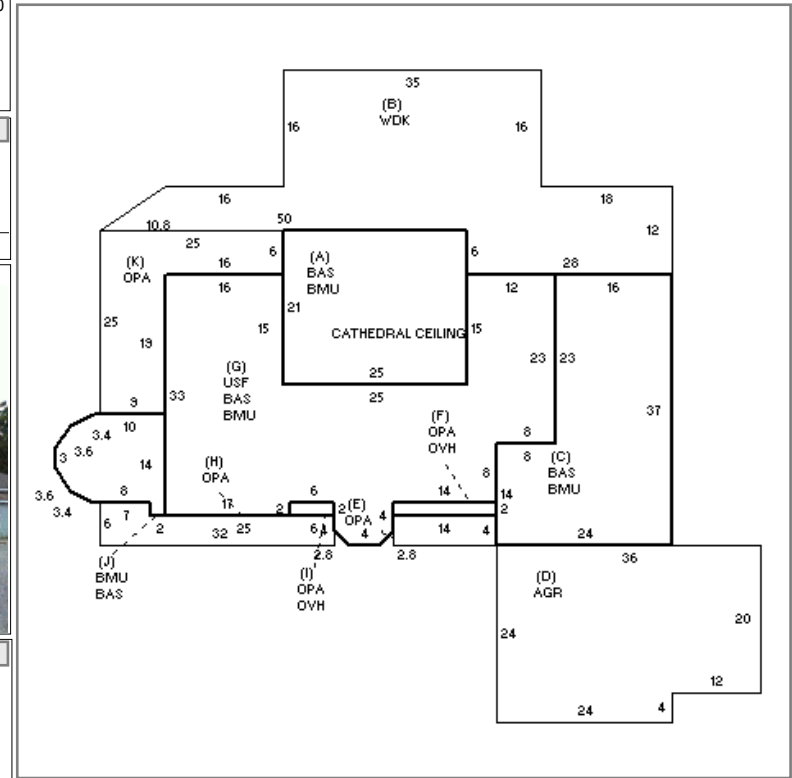

DETACHED

BUILDING

YEAR BLT	1994	SIZE ADJ	0.985
NET AREA	4,001	DETAIL ADJ	1.000
\$NLA(RCN)	\$310	OVERALL	1.190
CAPACITY		UNITS	ADJ
STORIES	2	1.00	
ROOMS	11	1.00	
BEDROOMS	5	1.00	
BATHROOMS	2	1.00	
FIXTURES	13	1.00	
GARAGE CAPACITY	3	1.00	
% BSMT FINISH	0	1.00	
# OF HALF BATHS	1	1.00	
# OF UNITS	1	1.00	

ELEMENT	CD	DESCRIPTION	ADJ
FOUNDATION	4	FLR/WALL(FULL)	1.00
EXT COVER	1	WOOD SHINGLE	1.02
ROOF SHAPE	2	HIP	1.02
ROOF COVER	1	ASPH/COMP SHIN	1.00
FLOOR COVER	1	HARDWOOD	1.02
INT. FINISH	2	DRYWALL	1.00
HEATING/COOLING	9	WARM-COOL AIR	1.03
FUEL SOURCE	1	OIL	1.00
USE	0		1.00

S	BAT	T	DESCRIPTION	UNITS	YB	ADJ PRICE	RCN
+	BMU	N	BSMT UNFINISHED	2,679		43.51	116,574
A	BAS	L	BASE AREA	525	1994	260.21	136,609
B	WDK	N	WOOD DECK	1,169		33.80	39,513
D	AGR	N	ATT GARAGE	816		87.31	71,243
+	OPA	N	OPEN PORCH	559		93.13	52,058
+	OVH	L	OVERHANG	40	1994	286.57	11,463
G	USF	L	UPPER STORY FIN	1,282	1994	164.52	210,914
+	BAS	L	BASE AREA	2,154	1994	260.21	560,489
F21	O		FPL 2S 1OP	1		13,939.40	13,939
FIX	O		XTRA FIXTURES	8		3,369.93	26,959

TOTAL RCN	1,239,760
CONDITION ELEM	CD
EXTERIOR	A
INTERIOR	A
KITCHEN	A
BATHS	A
HEAT	A
ELECT	A
EFF.YR/AGE	1999 / 23
COND	20 20 %
FUNC	0
ECON	0
DEPR	20 % GD 80
RCNLD	\$991,800