

Key: 8822

Town of Bourne - Fiscal Year 2024

12/18/2023 6:02 pm SEQ #: 9.009

LEGAL

LAND

DETACHED

BUILDING

CURRENT OWNER				PARCEL ID				LOCATION			
CLARK VIRGINIA B 25 W SUNSET AVE PHILADELPHIA, PA 19118				42.0-62-0				321 WINGS NECK RD			
TRANSFER HISTORY				DOS	T	SALE PRICE	BK-PG (Cert)				
CLARK VIRGINIA B				04/22/2014	F	10	28098-137				
TAYLOR LANE JR ETUX				04/10/2013	F	10	27280-309				
TAYLOR VIRGINIA B				06/30/2004	QS	868,500	18781-317				

CLASS	CLASS%	DESCRIPTION		BN ID	BN	CARD	
1010	100	SINGLE FAMILY			1	1 of 1	
PMT NO	PMT DT	TY	DESC	AMOUNT	INSP	BY	1st %
19086		3	ALT/RENO		01/06/2022	TL	100 100
08416	02/07/2019	15	INSULATE/WEA	5,032			100 100
	08/07/2008	4	DETACH.STRUC				100 100

CD	T	AC/SF/UN	Nbhd	Infl1	N Index	ADJ BASE	SAF	Topo	Lpi	VC	CREDIT AMT	ADJ VALUE				
100	S	80,000	12	1.00	100	1.00	100	1.00	659,960	0.64	A	1.00	WNA	2.80		781,650
300	A	0.823	12	1.00	100	1.00	100	1.00	45,640	1.00	A	1.00	WNA	2.80		37,560

TOTAL	2.660 Acres		ZONING	2	FRNT	0	ASSESSED	CURRENT	PREVIOUS
Nbhd	WINGS NCK		N O T E	TWO FRONTAGES			LAND	819,200	725,000
Infl1	AVG			BUILDING	403,100	356,700			
N_Index	AVG			DETACHED	3,600	3,300			
							OTHER	0	0
							TOTAL	1,225,900	1,085,000

TY	QUAL	COND	DIM/NOTE	YB	UNITS	ADJ PRICE	RCNLD
SHF	G	1.20	10 0.90		192	19.14	3,300
CAN	G	1.20	10 0.90		48	5.88	300

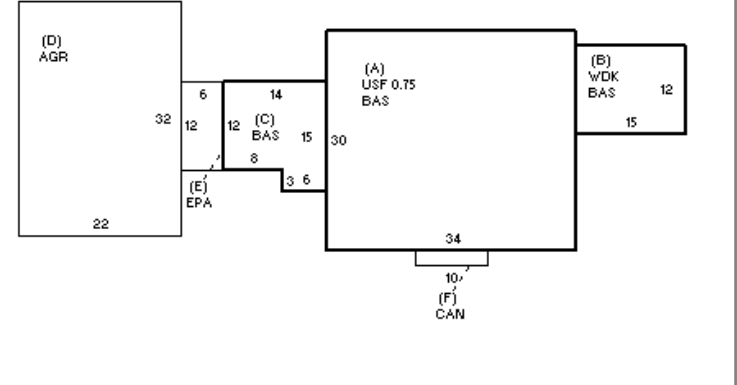

BUILDING	CD	ADJ	DESC	MEASURE	1/6/2022	TL
MODEL	1		RESIDENTIAL	LIST	1/6/2022	EST
STYLE	4	1.05	CAPE [100%]	REVIEW		
QUALITY	A	1.00	AVERAGE [100%]			
FRAME	1	1.00	WOOD FRAME [100%]			

BLDG COMMENTS

YEAR BLT	1946	SIZE ADJ	1.005	ELEMENT	CD	DESCRIPTION	ADJ	S	BAT	T	DESCRIPTION	UNITS	YB	ADJ PRICE	RCN	TOTAL RCN	468,691
NET AREA	2,151	DETAIL ADJ	1.000	FOUNDATION	1	PIER	1.00	+	BAS	L	BASE AREA	1,386	1946	209.70	290,649	CONDITION ELEM	CD
\$NLA(RCN)	\$218	OVERALL	1.110	EXT COVER	1	WOOD SHINGLE	1.02	A	USF	L	UPPER STORY FIN	765	1946	121.30	92,793	EXTERIOR	G
				ROOF SHAPE	1	GABLE	1.00	B	WDK	N	WOOD DECK	180		39.02	7,024	INTERIOR	A
				ROOF COVER	1	ASPH/COMP SHIN	1.00	D	AGR	N	ATT GARAGE	704		64.85	45,656	KITCHEN	G
				FLOOR COVER	2	SOFTWOOD	1.02	E	EPA	N	ENCLOSED PORCH	72		113.10	8,144	BATHS	G
				INT. FINISH	1	PLASTER	1.00	F	CAN	N	CANOPY	20		17.24	345	HEAT	A
				HEATING/COOLING	2	HOT WATER	1.02	F21	O	O	FPL 2S 1OP	1		9,826.90	9,827	ELECT	U
				FUEL SOURCE	1	OIL	1.00	FIX	O	O	XTRA FIXTURES	6		2,375.75	14,255		
				USE	0		1.00										

EFF. YR/AGE	2005 / 17	
COND	14	14 %
FUNC	0	
ECON	0	
DEPR	14	% GD 86
RCNLD	\$403,100	