

Key: 8949

Town of Bourne - Fiscal Year 2024

12/18/2023 6:02 pm SEQ #: 9.150

LEGALS

CURRENT OWNER				PARCEL ID				LOCATION			
ANDERSON MARK W & DEBRA A C/O ANDERSON TOES IN THE WATER 18 MICHAEL RD POCASSET, MA 02559				43.0-18-0				18 MICHAEL RD			
TRANSFER HISTORY				DOS	T	SALE PRICE	BK-PG (Cert)				
ANDERSON TOES IN THE WATE				11/24/2023	F	100	36102-262				
ANDERSON MARK W & DEBRA A				12/28/2017	U	215,000	30991-208				
TENNEY GAIL E				04/20/2012	H	205,000	26265-215				

CLASS	CLASS%	DESCRIPTION			BN ID	BN	CARD
1010	100	SINGLE FAMILY				1	1 of 1
PMT NO	PMT DT	TY	DESC	AMOUNT	INSP	BY	1st %
EXB-21-82	02/04/2021	15	INSULATE/WEA	3,044			100 100
18278	04/11/2018	9	DECK	1,200			100 100
17789	09/26/2017	3	ALT/RENO	8,000			100 100
16855	10/03/2016	4	DETACH.STRUC	1,240			100 100
09015	01/13/2009	3	ALT/RENO	11,900	06/15/2009	TL	100 100

LAND

CD	T	AC/SF/UN	Nbhd	Infl1	N Index	ADJ BASE	SAF	Topo	Lpi	VC	CREDIT AMT	ADJ VALUE
100	S	20,005	11	1.00	100	1.00	100	1.00			271,055	212,770

TOTAL	19,994 SF	ZONING	1	FRNT	0	ASSESSED	CURRENT	PREVIOUS
Nbhd	POC	NOTE	LAND	212,800	180,100			
Infl1	AVG		BUILDING	300,000	265,600			
N_Index	AVG		DETACHED	1,800	1,700			
			OTHER	0	0			
			TOTAL	514,600	447,400			

DETACHED

TY	QUAL	COND	DIM/NOTE	YB	UNITS	ADJ PRICE	RCNLD
SHF	A	1.00	10 0.90 10 X 12	2018	120	16.42	1,800



BLDG COMMENTS

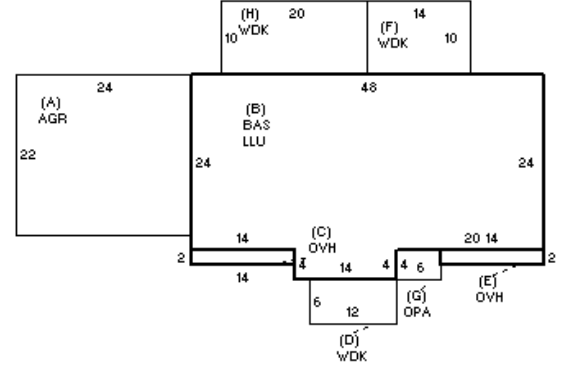

BUILDING

BUILDING	CD	ADJ	DESC	MEASURE	8/29/2018	BC
MODEL	1		RESIDENTIAL	LIST	8/29/2018	EST
STYLE	2	1.00	RAISED RANCH [100%]	REVIEW		
QUALITY	A	1.00	AVERAGE [100%]			
FRAME	1	1.00	WOOD FRAME [100%]			

UNIT

YEAR BLT	1980	SIZE ADJ	1.010
NET AREA	1,868	DETAIL ADJ	1.000
\$NLA(RCN)	\$209	OVERALL	1.020
CAPACITY		UNITS	ADJ
STORIES	1	1.00	
ROOMS	5	1.00	
BEDROOMS	2	1.00	
BATHROOMS	2	1.00	
FIXTURES	8	1.00	
GARAGE CAPACITY	2	1.00	
% BSMT FINISH	10	1.00	
# OF HALF BATHS	0	1.00	
# OF UNITS	1	1.00	

ELEMENT	CD	DESCRIPTION	ADJ	S	BAT	T	DESCRIPTION	UNITS	YB	ADJ PRICE	RCN
FOUNDATION	4	FLR/WALL(FULL)	1.00	A	AGR	N	ATT GARAGE	528		63.67	33,619
EXT COVER	10	VERT BOARD	1.00	B	LLU	N	LOWER LEVEL UNF	1,208		32.04	38,710
ROOF SHAPE	1	GABLE	1.00	B	BAS	L	BASE AREA	1,208	1980	193.66	233,940
ROOF COVER	1	ASPH/COMP SHIN	1.00	+	OVH	L	OVERHANG	56	1980	186.58	10,448
FLOOR COVER	3	W/W CARPET	1.00	+	WDK	N	WOOD DECK	412		22.00	9,066
INT. FINISH	2	DRYWALL	1.00	G	OPA	N	OPEN PORCH	24		97.95	2,351
HEATING/COOLING	2	HOT WATER	1.02	LLF	L	L	LOWER LEVEL FIN	604	1980	63.57	38,396
FUEL SOURCE	1	OIL	1.00	F11	O	O	FPL 1S 1OP	2		8,260.15	16,520
USE	0		1.00	FIX	O	O	XTRA FIXTURES	3		2,193.97	6,582

TOTAL RCN	389,631
CONDITION ELEM	CD
EXTERIOR	A
INTERIOR	A
KITCHEN	A
BATHS	A
HEAT	A
ELECT	A
EFF.YR/AGE	1996 / 26
COND	23 23 %
FUNC	0
ECON	0
DEPR	23 % GD 77
RCNLD	\$300,000