

Key: 9024

Town of Bourne - Fiscal Year 2024

12/18/2023 6:02 pm SEQ #: 9.224

LEGALS

LAND

DETACHED

BUILDING

CURRENT OWNER				PARCEL ID				LOCATION			
KEARNEY FRANCIS G JR TRS FRANCIS G KEARNEY JR TRUST PO BOX 3436 POCASSET, MA 02559				43.1-13-0				446 BARLOWS LANDING RD			
TRANSFER HISTORY				DOS	T	SALE PRICE	BK-PG (Cert)				
KEARNEY FRANCIS G JR TRS				03/23/2021	F	100	33923-56				
KEARNEY FRANCIS G JR & SH				09/06/2013	F	1	27672-276				
KEARNEY FRANCIS G JR ETUX				11/14/1979	QS		3014-13				

CLASS	CLASS%	DESCRIPTION			BN ID	BN	CARD	
1010	100	SINGLE FAMILY				1	1 of 1	
PMT NO	PMT DT	TY	DESC	AMOUNT	INSP	BY	1st	%
03315	05/27/2003	2	ADDITIONS	22,000	10/25/2005	TL	100	100
970366	07/11/1997	6	FENCE	500	05/06/1998	JS	100	100
960262	06/13/1996	2	ADDITIONS	13,760	12/16/1996	JC	100	100
960176	05/06/1996	2	ADDITIONS	29,400	12/16/1996	JC	100	100

CD	T	AC/SF/UN	Nbhd	Infl1	N Index	ADJ BASE	SAF	Topo	Lpi	VC	CREDIT AMT	ADJ VALUE
100	S	13,000	11	1.00	100	1.00	100	1.00				522,080

TOTAL	12,981 SF	ZONING	1	FRNT	0	ASSESSED	CURRENT	PREVIOUS
Nbhd	POC	NOTE	LAND	522,100	462,100			
Infl1	AVG		BUILDING	475,300	376,200			
N_Index	AVG		DETACHED	700	400			
			OTHER	0	0			
		<b>TOTAL</b>		<b>998,100</b>	<b>838,700</b>			

TY	QUAL	COND	DIM/NOTE	YB	UNITS	ADJ PRICE	RCNLD
SHF	E	1.90	10 0.90			0.00	
OPS	E	1.90	10 0.90		24	31.92	700



BUILDING	CD	ADJ	DESC	MEASURE	8/1/2023	SL
MODEL	1		RESIDENTIAL	LIST	8/1/2023	EST
STYLE	1	0.95	RANCH [100%]	REVIEW	8/1/2023	SL
QUALITY	+	1.05	AVERAGE + [100%]			
FRAME	1	1.00	WOOD FRAME [100%]			

YEAR BLT	1960	SIZE ADJ	1.005	ELEMENT	CD	DESCRIPTION	ADJ	S	BAT	T	DESCRIPTION	UNITS	YB	ADJ PRICE	RCN
NET AREA	2,456	DETAIL ADJ	1.000	FOUNDATION	3	FOUN. WALL	1.00	+	BAS	L	BASE AREA	1,240	1960	190.53	236,260
\$NLA(RCN)	\$236	OVERALL	1.000	EXT COVER	2	CLAPBOARD	1.00	B	OPA	N	OPEN PORCH	6		100.25	602
				ROOF SHAPE	1	GABLE	1.00	D	BIG	N	BUILT-IN GARAGE	800		77.82	62,259
				ROOF COVER	1	ASPH/COMP SHIN	1.00	D	USF	L	UPPER STORY FIN	800	1996	114.74	91,793
				FLOOR COVER	6	TILE	1.02	+	DKC	N	DECK-COMPOSITE	832		64.82	53,933
				INT. FINISH	2	DRYWALL	1.00	F	SOL	N	SOLARIUM	196		101.14	19,823
				HEATING/COOLING	9	WARM-COOL AIR	1.03	H	ASH	N	ATT SHED	30		26.24	787
				FUEL SOURCE	2	GAS	1.00	I	BAS	L	BASE AREA	416	1996	190.53	79,262
				USE	0		1.00	F11	O	FPL 1S 1OP	1		8,461.00	8,461	
								FIX	O	XTRA FIXTURES	6		2,247.33	13,484	
								JAC	O	JACUZZI	1		12,958.50	12,959	

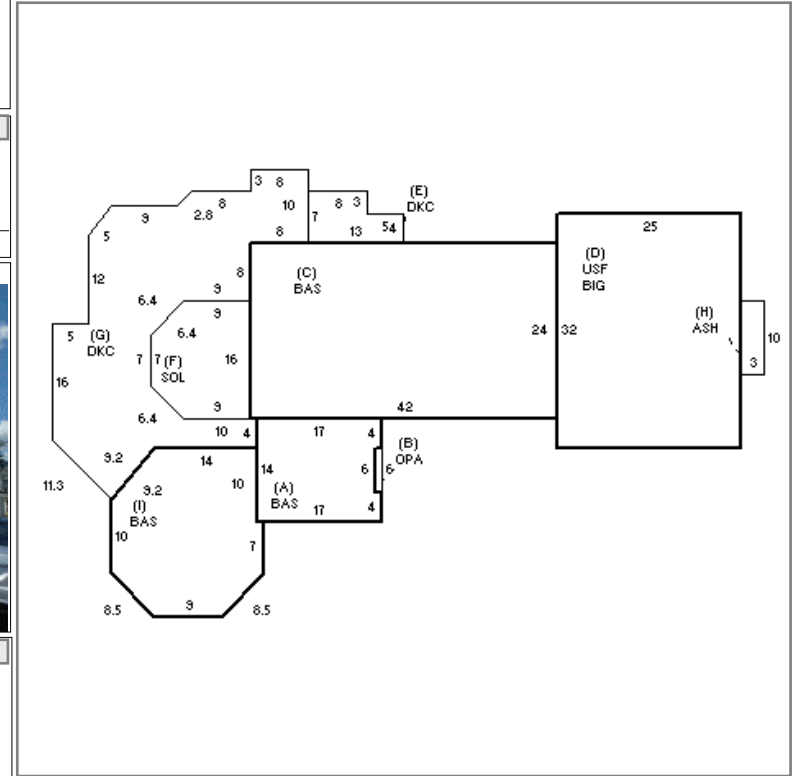

BLDG COMMENTS	
---------------	--

TOTAL RCN	579,621
CONDITION ELEM	CD
EXTERIOR	G
INTERIOR	G
KITCHEN	A
BATHS	A
HEAT	A
ELECT	A
EFF.YR/AGE	2001 / 21
COND	18 18 %
FUNC	0
ECON	0
DEPR	18 % GD 82
RCNLD	\$475,300